



®



# FIBER & TELECOM CONSTRUCTION

*Connecting You To Your Best Future*

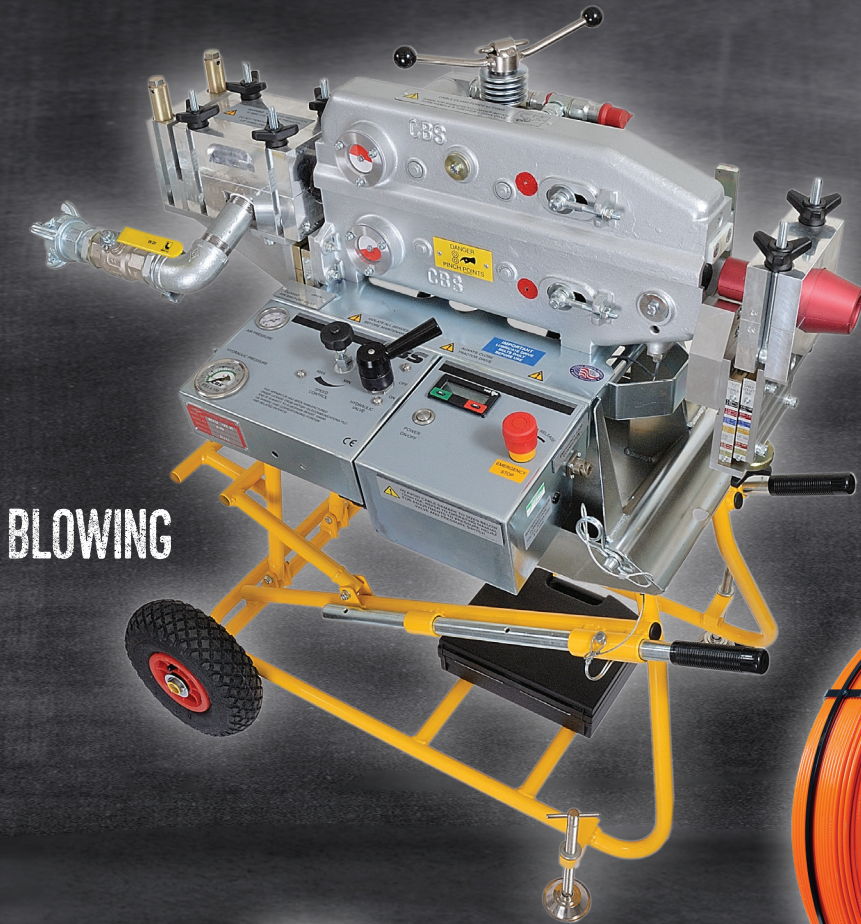

**BLOWING**

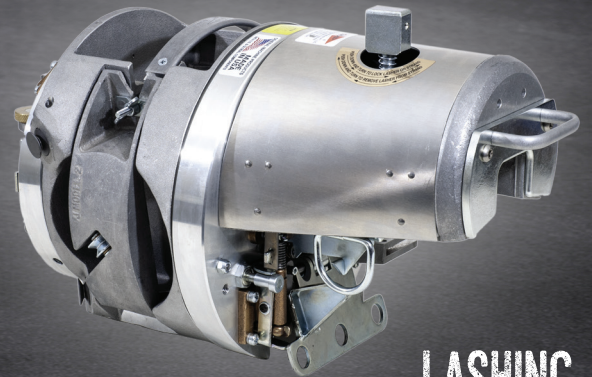

**LASHING**



**RODDING**



**PULLING**

SPRING 2025

# IN THE KNOW

The Tornado Cable Blowing Machine is easily converted to a tube blowing machine that will blow up to 5 microducts at a time.

Accessory configurations available for 10, 12 and 12.7mm tubes. Please call the factory for details.



## Hurricane Cable Blowing Machine

Advanced Data Logging System Measures & Records:

- Distance
- GPS Location
- Speed
- Force
- Environmental Conditions



*See more about the Hurricane on page 10*



## General Machine Products (KT), LLC

General Machine Products, a pioneer in the aerial and underground outside plant (OSP) tools, is leading the way with innovative fiber optic cable blowing and pulling products.

### TABLE OF CONTENTS

Cable Blowing	4-20	Aerial Tools	35-37
Line Blowing	21	Aerial Stringing	38
Blowing Accessories	22-23	Cable Cutters	39
Cable Pulling	24-25	Manhole Tools	40-41
Duct Rodding	26	Cable Pushing	42
Duct Rod Accessories	27	Underground Tools	42-43
Duct Rod Pushing	28	Reel Handling	44
Cable Pulling Accessories	29-31	Reels	45
Cable Lashing	32-34	Pole Trailer Light Bar	46
		Umbrellas	47

### About Us

Founded by engineer George M. Pfundt in 1936, GMP started operations in a downtown Philadelphia building as a specialty machine shop doing work for the local Bell Telephone company and for the electric utility company. GMP expanded to a production shop after landing a contract with Western Electric Company and, subsequently, forming a close relationship with Bell Telephone Laboratories in Murray Hill, NJ, which enabled it to manufacture prototypes of products for experimental use within the Bell System.

GMP's 100,000-square-foot manufacturing plant in Trevose is equipped with a full complement of technologically advanced machine tools manned by a well-trained team of craftspeople. Our own engineering staff conduct research & development of GMP's products using computer aided design, a prototype fabrication shop and an on-site testing facility.

In 2004, CBS Products joined forces with GMP to further enhance the global reach and breadth of our outside plant equipment capabilities. As of June 2017 the business of GMP Tools and CBS Products were acquired by Klein Tools of the USA. Renamed GMP Products (KT), LLC, we continue to be the same engineering talent and innovative solution providers.

GMP continues to make investments in new product R&D, state-of-the-art manufacturing, quality assurance, distribution and inventory control techniques, and physical plant, in order to maintain its manufacturing leadership position and its continuing ability to anticipate and meet the changing needs of work crews in the field who rely on the ruggedness, practicality and safety of GMP equipment. As our quality policy statement affirms: "GMP supplies defect-free products and service, on time, which meet its customers' expectations."

Member of



# BLOWING MACHINE COMPARISON

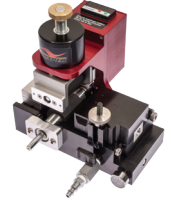
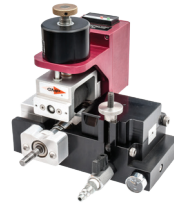

	MicroDrive	Gentle Air	AccelAir 3	Whisper
<b>Cable Diameter:</b>	2.6 - 5mm (0.102 - 0.196")	1.0 - 3.0mm (0.039 - 0.118")	.8 - 5.0mm (.03 - .20")	3 - 8.5mm (.11 - .33")
<b>Tube Size (O.D.):</b>	7.0, 8.0, 8.5, 10.0, 12.0, 12.7, 14.0mm	4 to 7mm (0.158 to 0.275")	3 - 12mm (.12 - .47")	4 - 18mm (.15 - .63")
<b>Flat Drop Compatible</b>	No	No	No	Yes with optional kit
<b>EABF® Compatible</b>	Yes	No	No	No
<b>Cable Speed (Adjustable):</b>	0 - 300 ft/min (0 - 90 m/min)	0 - 300 ft/min (0 - 90 m/min)	0 - 165 ft/min (0 - 50 m/min) with buckle detection  0 - 328 ft/min (0 - 100 m/min) no buckle detection	0 - 300 ft/min (0 - 90 m/min)
<b>Max Air Pressure/ Volume:</b>	220 psi (15 bar) 35 cfm (1 m³/min)	220 psi (15 bar) 35 cfm (1 m³/min)	220 psi (15 bar) 8.5 cfm (.24 m³/min)	220 psi (15 bar) 35 cfm (1 m³/min)
<b>Drive:</b>	Drive Wheel	Drive Roller	Drive Wheel	Drive Roller
<b>Power:</b>	Vari Speed Drill	Vari Speed Drill	110/220 VAC or Battery	Vari Speed Drill
<b>Cable Safety</b>	Magnetic Torque Control	Friction Torque Control	Buckle Protection	Torque Control via Drill
<b>Length:</b>	5.6" (143mm)	9.7" (246mm)	4.7" (120mm)	9.7" (246mm)
<b>Width:</b>	9.7" (248mm)	8.1" (206mm)	7.2" (184mm)	8.1" (206mm)
<b>Height:</b>	6.6" (169mm)	8.5" (216mm)	6.5" (166mm)	8.5" (216mm)
<b>Weight:</b>	6 lbs. (3.1kg)	12 lbs. (5.4kg)	6.6 lbs. (3kg)	12 lbs. (5.4kg)
<b>Part Number – Base</b>	89850	89916	89601	89910
<b>Part Number – Plus</b>	-----	89901	-----	89897
<b>Part Number – Max</b>	-----	-----	-----	90064

**Base** outfitted blowers come with 1 cable and seal size

**Plus** outfitted blowers come with 3 most popular cable and seal sizes

**Max** outfitted blowers come with every available cable and seal size

**Up to 30% savings on accessories when purchasing the Plus or Max**

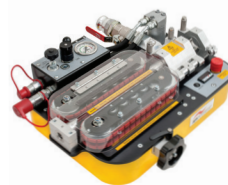

Whisper Flat Drop	AirStream	Hurricane	JetStream®	Tornado
call factory	2.5 - 11mm (.10 - .43")	2.5 - 14mm (.10 - .55")	<b>3</b> 4 - 20mm (.6 - .79")	<b>1</b> 5.84 - 34mm (.23 - 1.34")
4 - 18mm (.15 - .63")	5-18mm (.20 - .71")	5 - 25mm (.20 - .98")	10 - 50mm O.D. (.75 - 1.50" SDR)	12 - 63mm O.D. (.75 - 2.00" SDR)
Yes	Yes	Yes	No	No
No	No	No	No	No
0 - 300 ft/min (0 - 90 m/min)	0 - 262 ft/min (0 - 80 m/min)	0 - 280 ft/min (0 - 85m/min)	0 - 280 ft/min (0 - 85 m/min)	0 - 300 ft/min (0 - 90 m/min)
220 psi (15 bar) 35 cfm (1 m <sup>3</sup> /min)	220 psi (15 bar) 35 cfm (1 m <sup>3</sup> /min)	220 psi (15 bar) 150 - 450 cfm (12 m <sup>3</sup> /min)	<b>2</b> 220 psi (15 bar) 150 - 450 cfm (12 m <sup>3</sup> /min)	<b>2</b> 175 psi (12 bar) 150 - 450 cfm (4 - 12 m <sup>3</sup> /min)
Drive Roller	Belts	Belts	Belts	Belts
Vari Speed Drill	110/220 VAC	110/220 VAC	Gas/Hydraulic	Gas/Hydraulic
Torque Control via Drill	Electronic Torque Control	Electronic Torque Control	Hydraulic Pressure Sensing	Hydraulic Pressure Sensing
9.7" (246mm)	18.1" (460mm)	21.6" (550mm)	24.5" (620mm)	42" (1070mm)
8.1" (206mm)	11.8" (300mm)	12.2" (310mm)	19" (484mm)	27" (690mm)
8.5" (216mm)	10.6" (270mm)	13.8" (350mm)	9.2" (233mm)	48.5" (1230mm)
12 lbs. (5.4kg)	33 lbs. (15kg)	53 lbs. (24kg)	68 lbs. (31kg)	155 lbs. (70kg)
89915	89300	90000	89950	89000
89895	89321	90055	90058	89099
-----	89327	90054	90059	89113

- 1** Micro duct (10,12 & 12.7mm O.D.) blowing available with add-on kit
- 2** Airflow is duct size dependent
- 3** 4 - 6mm fiber possible with dedicated belt

## Tornado Cable Blowing Machine

Designed to be safe, fast and effective, the Tornado Cable Blowing Machine installs fiber optic cable into pre-installed innerduct or direct buried innerduct. A conversion kit allows the Tornado to place either 12.7, 12/10mm or 10/8mm micro ducts into innerduct as well.

Comprised of an aluminum air box and cable pusher, the Tornado uses compressed air to install the cable with or without a missile. In operation, the hydraulically powered, belt drive system controls the fiber optic cable as it is propelled by compressed air through the innerduct. An electronic monitoring system provides read-outs of speed and distance, helps protect cable against damage, and includes an emergency stop button.

The air box and cable pusher are mounted on a lightweight, tubular-steel frame that can be tilted at a 30-degree angle to the manhole, which significantly minimizes any bending of the innerduct and cable. The frame has retractable handles to permit ease of maneuverability, and adjustable rear legs that provide added stability on uneven terrain. This unit comes complete with a gasoline engine powered hydraulic power pack.

- P/N 89000 (Standard)** Weight: 350 lbs. (160kg)
- P/N 89001 (Metric Calibration)** Weight: 350 lbs. (160kg)
- P/N 89099 Plus** (come with 3 cable and seal sizes)
- P/N 89113 Max** (comes with every available cable and seal size)

## Specifications

### Operating Capacities

- Pushing Force: 0-220 lbs. (0-100kg)
- Pushing Speed: 0-300 ft/min (0-90m/min)
- Cable Size: .24-1.26" (6-32mm) O.D.
- Sub - Duct Size: 1/2-2 1/2" SDR (12-63mm) O.D.

### Pneumatic System

- Air Hose Bore (min): 1 1/4" (32mm)
- Operating Pressure: 175 psi (12 bar)
- Flow: The air supply should be filtered, cooled and dry
- For Ducts with an Inner Diameter of: Minimum Flow Acceptable @175 psi (12 bar)
- 0 up to 1" (0 up to 25mm) : 150 CFM (4m³/min)
- 1 up to 1 1/8" (26 up to 30mm) : 185 CFM (5m³/min)
- 1 1/8 up to 1 3/8" (31 up to 35mm) : 250 CFM (7m³/min)
- 1 3/8 up to 1 5/8" (36 up to 40mm) : 375 CFM (10m³/min)
- 1 5/8 up to 1 3/4" (41 up to 44mm) : 450 CFM (12m³/min)
- 1 3/4 up to 2" (44 up to 51mm) : 700 CFM 19m³/min

### Compressor Aftercooler

This unit has been designed as a stand-alone aftercooler for portable gas and diesel compressors. It delivers quality air to equipment, free of harmful condensed moisture. It will cool the compressed air to within 20° of ambient temperature. Can be used on most gas or diesel portable compressor when sized correctly.

	P/N 89060	P/N 89065
<b>Max Flow</b>	250 CFM	400 CFM
<b>Max Pressure</b>	200 psig	200 psig
<b>Max Pressure Drop</b>	5 psig	5 psig
<b>Fan Power Req.</b>	12v x 17.5a	24v x 9.6a *
<b>Dimensions (in.)</b>	24 x 19 x 32	48 x 24 x 30
<b>Weight</b>	70 lbs.	170 lbs.

\* 12v available upon request



P/N 89060



P/N 89065



P/N 70493



P/N 70494

### Tornado Cooler Adapter Kits

**P/N 70493** - All fittings and hoses to connect a 4 jaw compressor to the 89065 cooler and then to the Tornado cable blower.

**P/N 70494** - All fittings to configure the 89065 cooler to connect to a 4 jaw hose on the inlet and outlet sides. (no hoses included)

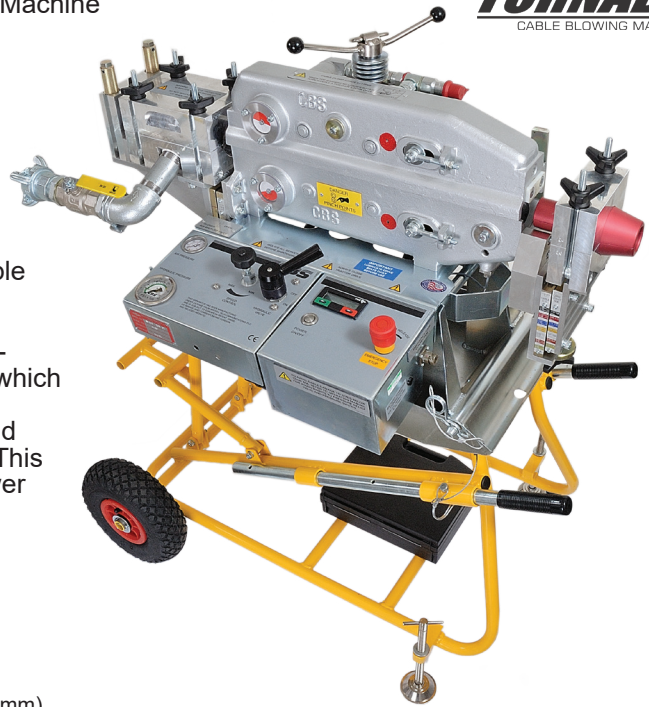

### Included Hydraulic Power Pack With Oil Cooler

- 4 gpm @ 1500 psi
- Integrated oil cooler for extended operation in high environmental temperatures.
- Unique suction circuit eliminates pulsation damage.
- Swing open frame provides excellent maintenance access to engine and hydraulics.

**P/N 32800** Weight: 145 lbs. (66kg)

PLUS  
MAX

PLUS  
MAX<sup>®</sup>

P/N	COMPONENT			
<b>DUCT CLAMPS</b>				
CHOOSE ONE SIZE CLAMP BELOW FOR STANDARD TORNADO				
89033	DUCT CLAMP 3/4"	1		
89021	DUCT CLAMP 1"	1		
89041	DUCT CLAMP 1.25"	1		
89061	DUCT CLAMP 1.50"	1		
89071	DUCT CLAMP 2"	1		
89077	DUCT CLAMP .5" SDR 11	1		
89293	DUCT CLAMP 1.25 SIDR PYRMD	1		
89037	DUCT CLAMP 1.25 SDR 11	1		
89097	DUCT CLAMP 2" TRU SDR	1		
89045	DUCT CLAMP TRU SDR 11.5	1		
89031	DUCT CLAMP 12 MM	1		
89035	DUCT CLAMP 12.7MM	1		
89039	DUCT CLAMP 14MM	1		
89025	DUCT CLAMP 16MM	1		
89075	DUCT CLAMP 18 MM	1		
89079	DUCT CLAMP 22 MM	1		
89055	DUCT CLAMP 25 MM	1		
89029	DUCT CLAMP 32 MM	1		
89057	DUCT CLAMP 38 MM	1		
89023	DUCT CLAMP 40 MM	1		
89063	DUCT CLAMP 50 MM	1		
<b>DUCT SEALS</b>				
CHOOSE ONE SIZE DUCT SEAL BELOW FOR STANDARD TORNADO				
89034	DUCT SEAL 3/4"	1		
89022	DUCT SEAL 1"	1		
89042	DUCT SEAL 1.25"	1		
89062	DUCT SEAL 1.50"	1		
89072	DUCT SEAL 2"	1		
89078	DUCT SEAL .5" SDR 11	1		
89294	DUCT SEAL 1.25" SIDR	1		
89038	COLLET DUCT SEAL 1.25" SDR 11	1		
89098	DUCT SEAL 2" TRU SDR	1		
89046	DUCT SEAL 1.25 TRU SDR 115	1		
89032	DUCT SEAL 12MM	1		
89036	DUCT SEAL 12.7MM	1		
89040	DUCT SEAL 14MM	1		
89026	DUCT SEAL 16MM	1		
89076	DUCT SEAL 18MM	1		
89080	DUCT SEAL 22 MM	1		
89056	DUCT SEAL 25 MM	1		
89030	DUCT SEAL 32 MM	1		
89058	DUCT SEAL 38 MM	1		
89024	DUCT SEAL 40 MM	1		
<b>CABLE COLLETS (6-34mm) &amp; GUIDES (6-12mm)</b>				
CHOOSE ONE SIZE CABLE COLLETS BELOW FOR STANDARD TORNADO				
89081	6-9mm (.23 - .35") (1 COLLET REQ.) (EXIT SIDE) <sup>1</sup>	1		
89082	6-9mm (.23 - .35") (1 GUIDE REQ.) (IN FEED SIDE) <sup>1</sup>	1		
89083	9-12mm (.35 - .47") (1 COLLET REQ.) (EXIT SIDE) <sup>1</sup>	1		
89084	9-12mm (.35 - .47") (1 GUIDE REQ.) (IN FEED SIDE) <sup>1</sup>	1		
89091	12-16mm (.47 - .63") (2 COLLETS REQ) <sup>2</sup>	2		
89092	16-20mm (.63 - .79") (2 COLLETS REQ) <sup>2</sup>	2		
89101	20-24mm (.79 - .95") (2 COLLETS REQ) <sup>2</sup>	2		
89102	24-28mm (.95 - 1.10") (2 COLLETS REQ) <sup>2</sup>	2		
89107	28-32mm (1.10 - 1.26") (2 COLLETS REQ) <sup>2</sup>	2		
89116	32-34mm (1.26 - 1.34") (2 COLLETS REQ) <sup>2</sup>	1		

<sup>1</sup> Collet and guide used together for this size cable  
<sup>2</sup> Same collet used on both in feed and exit side

Up to 30% savings on accessories when purchasing the Plus or Max

**Kit Part Numbers**  
**Base: 89000**  
**Plus: 89099**  
**Max: 89113**

P/N	COMPONENT			
<b>CABLE SEALS (6-34mm)</b>				
CHOOSE ONE SIZE CABLE SEAL BELOW FOR STANDARD TORNADO				
89085	6-7.5mm (.23 - .29") 10/PK	1		
89086	7.5-9mm (.29 - .35") 10/PK	1		
89087	9-10.5mm (.35 - .41") 10/PK	1		
89088	10.5-12mm (.41 - .47") 10/PK	1		
89093	12-14mm (.47 - .55") 10/PK	1		
89094	14-16mm (.55 - .63") 10/PK	1		
89095	16-18mm (.63 - .71") 10/PK	1		
89096	18-20mm (.71 - .79") 10/PK	1		
89103	20-22mm (.79 - .87") 10/PK	1		
89104	22-24mm (.87 - .95") 10/PK	1		
89105	24-26mm (.95 - 1.02") 10/PK	1		
89106	26-28mm (1.02 - 1.10") 10/PK	1		
89110	28-30 MM (1.10 - 1.18") 10/PK	1		
89111	30-32mm (1.18 - 1.26") 10/PK	1		
89112	32-34mm (1.26 - 1.34") 10/PK	1		
<b>CABLE SEAL PLUGS (6-34mm)</b>				
CHOOSE ONE SIZE CABLE SEAL PLUG BELOW FOR STANDARD TORNADO				
89125	6-7.5mm (.23 - .29")	1		
89126	7.5-9mm (.29 - .35")	1		
89127	9-10.5mm (.35 - .41")	1		
89128	10.5-12mm (.41 - .47")	1		
89129	12-14mm (.47 - .55")	1		
89130	14-16mm (.55 - .63")	1		
89131	16-18mm (.63 - .71")	1		
89132	18-20mm (.71 - .79")	1		
89133	20-22mm (.79 - .87")	1		
89134	22-24mm (.87 - .94")	1		
89135	24-26mm (.94 - 1.02")	1		
89136	26-28mm (1.02 - 1.10")	1		
89162	28-30mm (1.10 - 1.18")	1		
89164	30-32mm (1.18 - 1.26")	1		
89122	32-34mm (1.26 - 1.34")	1		
<b>EXTRAS</b>				
89155	CHAIN DRIVE TORNADO 6-12mm	2		
89140	CHAIN DRIVE TORNADO 12-34mm *			
89168	COLLET AND SEAL CARRYING CASE	7		
89168	COLLET AND SEAL CARRYING CASE	2		

\* Chain Drive that's included on Base unit

### How To Chose Your Tornado Component Kits

**When choosing the Plus Model: (included in price)**  
 Receive all components to blow the 3 most popular sizes  
**When choosing the Max Model:(included in price)**  
 Nothing to pick, you'll receive one of everything of most common sizes.



Now included with your Plus and Max Tornado blowing machines is the Klein Tools® MODbox™ Mobile Workstation.

### Supplied With All Machines

- Tornado Blowing Machine
- Hydraulic Power Pack
- Toolkit
- Manual

## Jetstream® Cable Blowing Machine

The JetStream® has been designed to provide maximum cable protection, combined with the performance and reliability of hydraulic drive. The profiled double drive belt system is driven by single 32 cc hydraulic motor, and is powered by same power pack with oil cooler as the Tornado which is included. The electronic monitoring system provides read-out of speed and distance, helps protect against duct obstructions and includes an emergency stop button.

The JetStream® is adjustable to suit a wide range of cable diameters .16-.79" (4-20mm), and duct diameters of .75-1.50" SDR (10 - 50mm O.D.).

### Main Features

- Automatic cable centralizing
- Synchronous high grip profiled compliant drive belts
- Tabletop design
- Variable speed controls
- Digital cable speed and length monitoring
- Integral air valves and pressure gauges
- Polycarbonate safety guarding
- Low maintenance
- Wheeled travel case
- Tool kit



Now included with Plus and Max Options



LARGE WHEEL KIT INCLUDED  
Sold as add on kit for older units



Hydraulic Power Pack

P/N 89060



P/N 89060



P/N 89065

### Compressor Aftercooler

This unit has been designed as a stand-alone aftercooler for portable gas and diesel compressors. It delivers quality air to equipment, free of harmful condensed moisture. It will cool the compressed air to within 20° of ambient temperature. Can be used on most gas or diesel portable compressor when sized correctly.

### Hurricane Cooler Adapter Kits

**P/N 70493** - All fittings and hoses to connect a 4 jaw compressor to the 89065 cooler and then to the Tornado cable blower.

**P/N 70494** - All fittings to configure the 89065 cooler to connect to a 4 jaw hose on the inlet and outlet sides. (no hoses included)



P/N 70493



P/N 70494

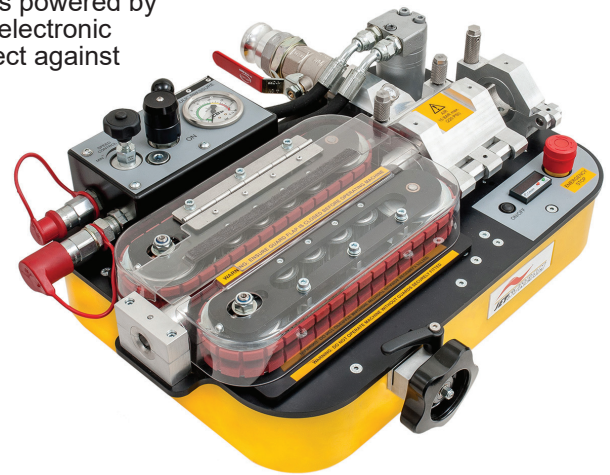

### Specifications

- Cable Diameter:** .16 to 79" (4-20mm) (1)
- Duct Size O.D.:** .75-1.50" SDR (10-50mm O.D.)
- Cable Speed:** 0-280 ft/min (0-85m/min)
- Air Pressure:** 220 psi (15 bar) 450 cfm (12m<sup>3</sup>/min)
- Power Req:** Included hydraulic power pack
- Width:** 19" (484mm)
- Length:** 24.5" (620mm)
- Height:** 9.2" (233mm)
- Net Weight:** 68 lbs. (31kg) (with case 132 lbs. 60kg)

(1) 4-16mm with small "V" belt  
6-20mm with large "V" belt

### Included Hydraulic Power Pack With Oil Cooler

- 4 gpm @ 1500 psi
- Integrated oil cooler for extended operation in high environmental temperatures.
- Unique suction circuit eliminates pulsation damage. Swing open frame provides excellent maintenance access to engine and hydraulics.

**P/N 32800** Weight: 145 lbs. (66kg)

	P/N 89060	P/N 89065
<b>Max Flow</b>	250 CFM	400 CFM
<b>Max Pressure</b>	200 psig	200 psig
<b>Max Pressure Drop</b>	5 psig	5 psig
<b>Fan Power Req.</b>	12v x 17.5a	24v x 9.6a *
<b>Dimensions (in.)</b>	24 x 19 x 32	48 x 24 x 30
<b>Weight</b>	70 lbs.	170 lbs.



PLUS  
MAX

P/N	COMPONENT			
<b>DUCT CLAMPS (.75-1.50)</b>				
<i>CHOOSE ONE SIZE CLAMP BELOW FOR STANDARD JETSTREAM</i>				
89960	DUCT CLAMP 3/4"	1		
89961	DUCT CLAMP 1"	1		
89962	DUCT CLAMP 1.25"	1		
89963	DUCT CLAMP 1.50"	1		
89905	DUCT CLAMP 14mm	1		
89908	DUCT CLAMP 10mm	1		
89959	DUCT CLAMP 12.7mm	1		
89964	DUCT CLAMP 12mm	1		
89965	DUCT CLAMP 16mm	1		
89966	DUCT CLAMP 18mm	1		
89958	DUCT CLAMP 22mm	1		
89967	DUCT CLAMP 25mm	1		
89968	DUCT CLAMP 32mm	1		
89969	DUCT CLAMP 40mm	1		
89970	DUCT CLAMP 50mm	1		
<b>DUCT SEALS (.75-1.50)</b>				
<i>CHOOSE ONE SIZE DUCT SEAL BELOW FOR STANDARD JETSTREAM</i>				
89972	DUCT SEAL 3/4"	1		
89973	DUCT SEAL 1"	1		
89974	DUCT SEAL 1.25"	1		
89975	DUCT SEAL 1.50"	1		
89906	DUCT SEAL 14mm	1		
89909	DUCT SEAL 10mm	1		
89983	DUCT SEAL 12.7mm	1		
89976	DUCT SEAL 12mm	1		
89977	DUCT SEAL 16mm	1		
89978	DUCT SEAL 18mm	1		
89971	DUCT SEAL 22mm	1		
89979	DUCT SEAL 25mm	1		
89980	DUCT SEAL 32mm	1		
89981	DUCT SEAL 40mm	1		
89982	DUCT SEAL 50mm	1		
<b>CABLE COLLET ASSEMBLIES (4-20mm)</b>				
<i>CHOOSE ONE SIZE CABLE COLLETS BELOW FOR STANDARD JETSTREAM</i>				
89890	4-6 MM (.16 - .23")	1		
89891	6-9 MM (.23 - .35")	1		
89892	9-12 MM (.35 - .47")	1		
89893	12-16 MM (.47 - .63")	1		
89894	16-20 MM (.63 - .79")	1		
<b>CABLE SEALS (4-20mm)</b>				
<i>CHOOSE ONE SIZE CABLE SEAL BELOW FOR STANDARD JETSTREAM</i>				
89089	4-5 MM (.16 - .20") 10/PK	1		
89090	5-6 MM (.20 - .23") 10/PK	1		
89085	6-7.5 MM (.23 - .29") 10/PK	1		
89086	7.5-9 MM (.29 - .35") 10/PK	1		
89087	9-10.5 MM (.35 - .41") 10/PK	1		
89088	10.5-12 MM (.41 - .47") 10/PK	1		
89093	3 12-14 MM (.47 - .55") 10/PK	1		
89094	14-16 MM (.55 - .63") 10/PK	1		
89095	16-18 MM (.63 - .71") 10/PK	1		
89096	18-20 MM (.71 - .79") 10/PK	1		
<b>CABLE SEAL PLUGS (4-20mm)</b>				
<i>CHOOSE ONE SIZE CABLE SEAL PLUG BELOW FOR STANDARD JETSTREAM</i>				
89123	4-5 MM (.16 - .20")	1		
89124	5-6 MM (.20 - .23")	1		
89125	6-7.5 MM (.23 - .29")	1		
89126	7.5-9 MM (.29 - .35")	1		
89127	9-10.5 MM (.35 - .41")	1		
89128	10.5-12 MM (.41 - .47")	1		
89129	12-14 MM (.47 - .55")	1		
89130	14-16 MM (.55 - .63")	1		
89131	16-18 MM (.63 - .71")	1		
89132	18-20 MM (.71 - .79")	1		
<b>EXTRAS</b>				
33772	CABLE DRIVE BELT 6-20mm			
89214	OPTION BELT 4-16MM CABLE	2		

Up to 30% savings on accessories when purchasing the Plus or Max



**How To Chose Your JetStream Component Kits**

**When choosing the Plus Model:** (items priced individually)  
 Receive all components to blow the 3 most popular sizes

**When choosing the Max Model:** (items priced individually)  
 Nothing to pick, you'll receive one of everything

The standard belt set supplied with all JetStreams is the 6-20mm. If you need a different size, order separately.

**Kit Part Numbers**  
**Base:** 89950  
**Plus:** 90058  
**Max:** 90059

**Supplied With All Machines**  
 JetStream Cable Blowing Machine  
 (2) 9V batteries for control  
 Hydraulic Power Pack  
 Travel Case for JetStream and accessories  
 Toolkit  
 Manual

## Hurricane Cable Blowing Machine

The Hurricane has been designed to maximize protection for micro cables with a compliant double drive concept, backed by the latest technology in servo controls to provide precise control of torque and speed. Single-person operation with safe, easy-to-operate ergonomic controls combines low maintenance and high reliability to form the machine's key features.

### Main Features

- Dual Digital servo motor drive system
- Advanced data logging system measures speed, force, distance, GPS location and environmental conditions
- Forward and reverse
- Installs an Industry leading range of cables with one machine
- Automatic Cable centralizing
- Synchronous high grip profiled compliant drive belts
- Vertical design with ergonomic controls for ease of operation
- Variable torque and speed controls via remote
- Single person operation
- Digital cable speed and length monitoring
- Auto stop facility when air stone fitted
- Integral air valve and pressure gauge
- Easy cable threading
- Polycarbonate safety guarding
- Lightweight and compact
- Low maintenance
- Low noise levels
- Travel case
- Tool Kit



### Specifications

<b>Cable Diameter:</b>	.10-.55" (2.5-14mm) O.D.
<b>Duct Size O.D.:</b>	.20-.98" SDR (5-25mm) O.D.
<b>Cable Speed:</b>	0-279 ft/min (85m/min)
<b>Air Pressure:</b>	220 psi (15 bar)
<b>Power Req:</b>	90-264VAC 50/60 Hz
<b>Width:</b>	12"
<b>Length:</b>	13 7/8"
<b>Height:</b>	13 7/8"
<b>Net Weight:</b>	53 lbs. (24kg)

## Air Compressor For Micro Fiber Cable Blowing Machines

The Air Compressor is designed specifically for use with our Micro Fiber Cable Blowing Machines. This reliable & efficient screw compressor, powered by a gasoline engine, provides a maximum working pressure of 220 psi (15 bar) with 35.3 cfm (1000 liters/m) flow. The compressor includes an after-cooler and water separator. The output air is filtered and conditioned to optimize the performance of our micro fiber cable blowing machines. The compressor package includes a hose that connects the compressor to the after-cooler and 50 foot 3/4" diameter air hose for after-cooler connection to the microfiber cable blowing machine.

**Order: P/N 89011** Weight: 487 lbs. (221kg)

Engine:	Honda® 21 hp
Fuel Cap.:	5 gal (20 liters)
Length:	42" (1070mm)
Width:	31" (800mm)
Height:	30" (780mm)
Weight:	487 lbs. (221kg)
	Compressor and After-Cooler



Air Compressor

After-Cooler and Water Separator

PLUS  
MAX

P/N	COMPONENT	PLUS	MAX
<b>DUCT CLAMP AND SEAL KIT</b>			
<i>CHOOSE ONE SIZE DUCT CLAMP AND SEAL KIT BELOW FOR STANDARD HURRICANE</i>			
90006	5MM DUCT		
90007	7MM DUCT		
90008	8MM DUCT		
90049	8.5MM DUCT		
90009	10MM DUCT		
90010	12MM DUCT		
90050	12.7MM DUCT		
90011	14MM DUCT		
90012	16MM DUCT		
90013	18MM DUCT		
90051	21.6MM DUCT		
<b>CABLE GUIDE KIT</b>			
<i>CHOOSE ONE SIZE CABLE GUIDES BELOW FOR STANDARD HURRICANE</i>			
90017	2.5-4MM		
90018	4-6MM		
90019	6-9MM		
90020	9-12MM		
90021	12-14MM		
<b>CABLE SEALS KIT</b>			
<i>CHOOSE ONE SIZE CABLE SEALS BELOW FOR STANDARD HURRICANE</i>			
90022	2.5-3MM		
90023	3-4MM		
90024	4-5MM		
90025	5-6MM		
90026	6-7.5MM		
90027	7.5-9MM		
90028	9-10.5MM		
90029	10.5-12MM		
90030	12-14MM		
<b>DRIVE BELTS</b>			
90043	2.5-9MM *		
90044	3-11MM (SUPPLIED & INSTALLED)		
90045	5-14MM *		
<b>EXTRAS</b>			
89434	DUCT ADAPTER 18MM TO 1" SDR		
70740	DUCT ADAPTER 18MM TO 26.6MM		

\* Part number 90043 and 90045 are ordered separately

### How To Chose Your Hurricane Component Kits

**When choosing the Plus Model: (included in price)**  
Receive all components to blow the 3 most popular sizes

**When choosing the Max Model: (included in price)**  
Nothing to pick, you'll receive one of everything

### Flat Drop Kit

Belts, collets and seals included for SST toneable / non-toneable and Essex toneable / non-toneable.

**P/N 90056**

Up to 30% savings on accessories when purchasing the Plus or Max

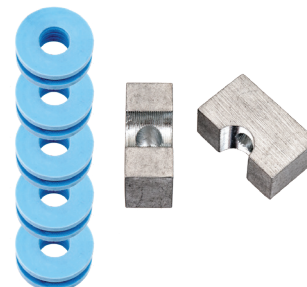

DUCT CLAMP AND SEAL KIT

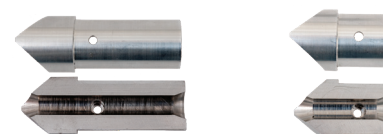

CABLE GUIDE KIT



CABLE SEALS

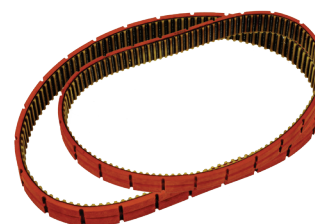

DRIVE BELTS

### Supplied With All Machines

- Hurricane Blowing Machine
- Remote
- Power Supply with Plug
- Tool Kit
- Carry Case
- Drive Belt 3-11mm cable diameter

<b>Kit Part Numbers</b>	
<b>Base:</b>	90000
<b>Plus:</b>	90055
<b>Max:</b>	90054

## Electric Airstream Cable Blowing Machine

The AirStream has been designed to maximize protection for microcables with a compliant double drive concept, backed by the latest technology in servo controls to provide precise control of torque and speed. Single person operation with safe, easy to operate ergonomic controls combines with low maintenance and high reliability to form the machine's key features. The AirStream is adjustable to suit a wide range of cable diameters 2.5-11mm.



### Main Features

- Automatic cable centralizing
- Synchronous high grip profiled compliant drive belts
- Tabletop design with ergonomic controls for ease of operation
- Forward and reverse
- Variable torque and speed controls
- Digital servo motor drive system
- Single person operation
- Digital cable speed and length monitoring
- Auto stop facility when air stone fitted
- Integral air valve and pressure gauge
- Easy cable threading
- Polycarbonate safety guarding
- Lightweight and compact
- Low maintenance
- Low noise levels
- Travel case

### Specifications

Cable Diameter:	2.5-11mm (.10 -.43")
Tube Size O.D.:	5 to 18mm (.20-.71")
Cable Speed (Adjustable):	0-262 ft/min (0-80m/min)
Air Pressure:	220 psi (15 Bar)
Power Requirement:	110/220 Volt AC
Width:	11.8" (300mm)
Length:	18.1" (460mm)
Height:	10.6" (270mm)
Net Weight:	33 lbs. (15kg)

- P/N 89300** Electric AirStream Blowing Machine Weight: 31 lbs. (14kg)
- P/N 89321** Plus (comes with 3 cable and seal sizes)
- P/N 89327** Max (comes with every available cable and seal size)

## Air Compressor For Micro Fiber Cable Blowing Machines

The Air Compressor is designed specifically for use with our Micro Fiber Cable Blowing Machines. This reliable & efficient screw compressor, powered by a gasoline engine, provides a maximum working pressure of 220 psi (15 bar) with 35.3 cfm (1000 liters/m) flow. The compressor includes an after-cooler and water separator. The output air is filtered and conditioned to optimize the performance of our micro fiber cable blowing machines. The compressor package includes a hose that connects the compressor to the after-cooler and 50 foot 3/4" diameter air hose for after-cooler connection to the microfiber cable blowing machine.

**Order: P/N 89011** Weight: 487 lbs. (221kg)

Engine:	Honda® 21 hp
Fuel Cap.:	5 gal (20 liters)
Length:	42" (1070mm)
Width:	31" (800mm)
Height:	30" (780mm)
Weight:	487 lbs. (221kg)
	Compressor and After-Cooler



Air Compressor

After-Cooler and Water Separator

Up to 30% savings on accessories when purchasing the Plus or Max

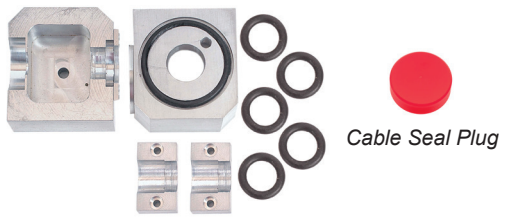

Tube Collet and Clamp Assemblies

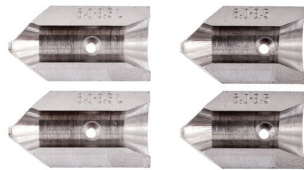

Cable Guide Assemblies

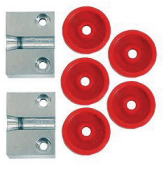

Cable Seal Collet Assemblies



Drive Belts

**Supplied With All Machines**

- Air Stream Cable Blowing Machine
- Travel Case for Air Stream and accessories
- Toolkit
- Manual

P/N	COMPONENT		PLUS	MAX
<b>TUBE COLLET AND CLAMP ASSEMBLIES (5-18MM)</b>				
<i>CHOOSE ONE SIZE BELOW FOR STANDARD AIR STREAM</i>				
89310	Collet Assy 5MM	1		
89311	Collet Assy 7MM	1		
89312	Collet Assy 8MM	1		
89319	Collet Assy 8.5MM	1		
89313	Collet Assy 10MM	1		
89314	Collet Assy 12MM	1		
89315	Collet Assy 12.7MM	1		
89316	Collet Assy 14MM	1		
89317	Collet Assy 16MM	1		
89318	Collet Assy 18MM	1		
<b>CABLE GUIDES (2.5-11MM)</b>				
<i>CHOOSE ONE SIZE DUCT SEAL BELOW FOR STANDARD AIR STREAM</i>				
89305	Guide Cable Assy 2.5MM (only)	1		
89306	Guide Cable Assy 2.5-3.0MM	1		
89307	Guide Cable Assy 3.0-6.4	1		
89303	Guide Cable Assy 6.0-8.5	1		
89304	Guide Cable Assy 8.5-11.0	1		
<b>CABLE SEALS (2.5-11MM)</b>				
<i>CHOOSE ONE SIZE CABLE SEAL BELOW FOR STANDARD AIR STREAM</i>				
89374	Seal Cable Assy 2.5-3.0	1		
89375	Seal Cable Assy 3.0-3.8	1		
89376	Seal Cable Assy 3.8-5.0	1		
89377	Seal Cable Assy 5.0-6.4	1		
89378	Seal Cable Assy 6.4-8.5	1		
89379	Seal Cable Assy 8.0-9.5	1		
89373	Seal Cable Assy 9.5-11.0	1		
<b>CABLE SEAL PLUG</b>				
<i>CHOOSE ONE SIZE CABLE SEAL PLUG BELOW FOR STANDARD AIR STREAM</i>				
32906	Plug Seal for AirStream	1		
<b>EXTRAS</b>				
89214	OPTION BELT 4-16MM CABLE	2		
89434	DUCT ADAPTER 18MM TO 1" SDR	1		
70740	DUCT ADAPTER 18MM TO 26.6MM	1		

**How To Chose Your AIR STREAM Component Kits**

**When choosing the Plus Model: (included in price)**  
 Receive all components to blow the 3 most popular sizes

**When choosing the Max Model: (included in price)**  
 Nothing to pick, you'll receive one of everything

The standard belt set supplied with all AIR STREAMS is the 6-20mm. If you need a different size, order separately.

**Kit Part Numbers**

**Base:** 89300

**Plus:** 89321

**Max:** 89327

Flat Drop Kit  
 P/N 89328

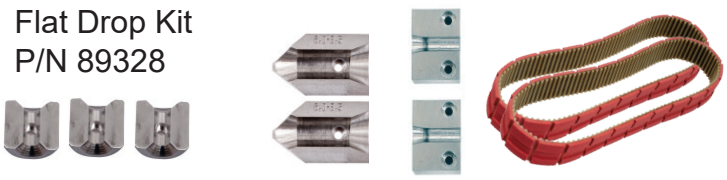

*Includes: 2 belts and collet for SST and Superior Essex*

**Cable Seal 3/pk**

- 89504 SST Tenable
- 89505 SST Non-Tenable
- 89519 Superior Essex Non-Tenable

## AccelAir 3 Blown Fiber Machine

The AccelAir 3 Blown Fiber Machine is the latest complement to the range of fiber optic blowing equipment available from GMP. Designed to suit the smaller end of fiber range from 2-12 fibers (.08-5mm dia.),



AccelAir 3 completes the range of Tornado, JetSteam, AirStream, Breeze and Whisper fiber blowing installation systems all from GMP. A

compact integrated fiber-blowing machine, the AccelAir 3 benefits from full automation and fiber management. Its sophisticated fiber protection is designed to help ensure that the blown fiber mechanical and optical integrity is maintained. The machine is self-contained and only requires an electrical supply and compressed air to operate.

### Main Features

- Installs cable diameters of .08-1.6mm with buckle protection and 1.7 to 5mm without buckle protection.
- Accommodates microduct sizes of 3-12mm. Contact GMP for custom sizes.
- Can be powered directly by the supplied 120/240v universal power supply or the AccelAir 3 compressor's built in power 24v power supply. Optional 24v battery pack available.
- Light weight, durable construction with precision machined parts
- Single person operation
- Digital cable speed and length monitoring.
- Integral air valve and pressure gauge
- Low maintenance
- Durable carrying case included

### P/N 89601

AccelAir 3 Blown Fiber Machine  
Weight: 6.6 lbs. (3kg)



### Specifications:

Cable Diameter:	0.8-5mm
Tube Size O.D.	3-12mm
Cable Speed (Adjustable):	0-165 ft/min (0-50m/min) with buckle detection
	0 - 328 ft/min (0-100 m/min) without buckle detection
Max Air Pressure:	220 psi (15 Bar) 8.5 cfm (.24m <sup>3</sup> /min)
Power Requirement:	120/220v to power supply, 24v from compressor or optional 24v battery pack
Width:	7.2" (184mm)
Length:	4.7" (120mm)
Height:	6.5" (166mm)
Net Weight:	6.6 lbs. (3kg)



*fitted with buckle plates for .8 to 1.6mm*

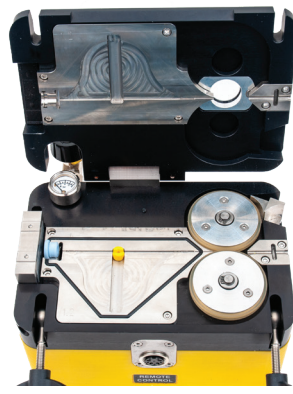

*fitted with blowing plates for 1.7 to 5mm*



*Durable carrying case included*

Up to 30% savings on accessories when purchasing the Plus or Max

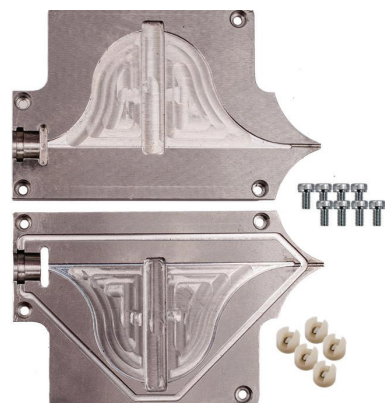

Buckle Plates

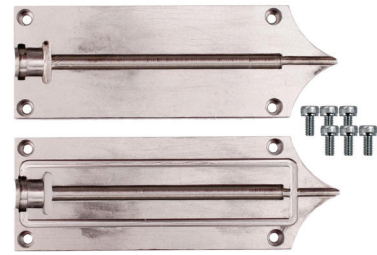

Blowing Plates



Tube Clamps and Seals

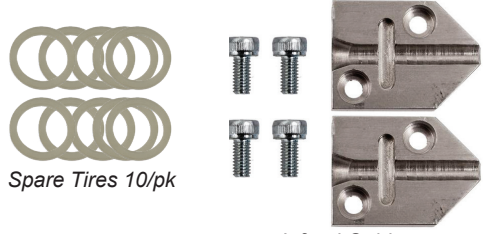

Spare Tires 10/pk

Infeed Guides

**Supplied With All Machines**

- AccelAir 3 Cable Blowing Machine
- Remote Control
- Toolkit
- Heavy-duty weatherproof case
- Manual

**Kit Part Numbers**  
**Base: 89500**  
**Plus: 89860**

PLUS

P/N	COMPONENT		
<b>BUCKLE PLATES</b>			
CHOOSE ONE SIZE BELOW FOR STANDARD ACCELAIR 3			
89440	1.0mm Buckle Plate	1	
89441	1.2mm Buckle Plate	1	
89442	1.4mm Buckle Plate	1	
89443	1.5mm Buckle Plate	1	
<b>BLOWING PLATES</b>			
CHOOSE ONE SIZE DUCT SEAL BELOW FOR STANDARD ACCELAIR 3			
89657	1.6mm Blowing Plate	1	
89658	1.7mm Blowing Plate	1	
89661	2.0mm Blowing Plate	1	
89662	2.1mm Blowing Plate	1	
89674	2.3mm Blowing Plate	1	
89666	2.5mm Blowing Plate	1	
89671	3.0mm Blowing Plate	1	
<b>TUBE CLAMPS AND SEALS</b>			
CHOOSE ONE SIZE DUCT SEAL BELOW FOR STANDARD ACCELAIR 3			
89491	3mm Tube Clamp and Seals	1	
89492	4mm Tube Clamp and Seals	1	
89493	5mm Tube Clamp and Seals	1	
89494	6mm Tube Clamp and Seals	1	
89495	7mm Tube Clamp and Seals	1	
89496	8mm Tube Clamp and Seals	1	
89497	8.5mm Tube Clamp and Seals	1	
89498	10mm Tube Clamp and Seals	1	
<b>INFEED GUIDES</b>			
CHOOSE ONE SIZE DUCT SEAL BELOW FOR STANDARD ACCELAIR 3			
89478	.8-2.0mm	1	
89479	2.0-3.0mm	1	
<b>DRIVE TIRES</b>			
CHOOSE ONE SIZE TIRE BELOW FOR STANDARD ACCELAIR 3			
89503	Up to 2.0mm	1	
89508	2mm-3.0mm	1	

**How To Chose Your ACCELAIR 3 Component Kits**

**When choosing the Base Model: (items priced individually)**

- Pick 1 Buckle plate or 1 Blowing plate
- Pick 1 Tube Clamp and Seal kit
- Pick 1 Infeed Guide

**When choosing the Plus Model: (included in price)**

Receive all components to blow the 3 most popular sizes



Air Compressor  
P/N 89011

## Whisper Microcable Blowing Machine

Now you can depend on the same GMP quality as our larger machines in a new smaller package...

The Whisper installs microcable and its versatility saves you money.

The design of the Whisper provides for quick and easy component changes for different cable or duct sizes. Its compact size and portable maneuverability make the Whisper ideally suited for either outside or in-building use.

The Whisper uses compressed air to install the cable. The drive roller, powered by most types of cordless drills (not included), control the microfiber as it is propelled into the microduct. An electronic monitoring system provides read-outs of speed and distance.

### Main Features

- Installs cable diameters of 2-8.5mm
- Flat Drop compatible. Call for details
- Accommodates microduct sizes of 4-18mm
- Uses most any variable speed 3/8" drill as a power source
- Light weight, durable construction with precision machined parts
- Single person operation
- Digital cable speed and length monitoring
- Integral air valve and pressure gauge
- Low maintenance
- Ideal for smaller jobs where a bigger machine is simply too much
- Travel bag included

### Specifications:

Cable Diameter:	2-8.5mm Round and various manufactures Flat Drop
Tube Size O.D.:	4-18mm
Cable Speed (Adjustable):	0-300 ft/min (0-90m/min)
Max Air Pressure:	220 psi (15 Bar)
Power Requirement:	Variable Speed Drill
Width:	8.1" (206mm)
Length:	9.7" (246mm)
Height:	8.5" (216mm)
Net Weight:	12 lbs. (5.4kg)

### Accessories:



Tripod Mount  
P/N 89945



Drill Stand  
P/N 89948



Bottled Nitrogen Kit  
P/N 89742



Whisper Air Supply Hose  
P/N 89949



Unit powered by customer supplied variable speed drill



Air Compressor  
P/N 89011







CABLE BLOWING

PLUS ROUND  
PLUS FLAT  
MAX

P/N	WHISPER ROUND CABLE			
<b>DUCT CLAMP AND SEAL KIT - Round Fiber &amp; Flat Drop</b>				
CHOOSE ONE SIZE BELOW FOR BASE WHISPER				
89918	4mm O.D.	1		
89919	5mm O.D.	1		
89926	7mm O.D.	1		
89927	8mm O.D.	1		
89920	8.5mm O.D.	1		
89922	10mm O.D.	1		
89923	12mm O.D.	1		
89921	12.7mm O.D.	1		
89928	14mm O.D.	1		
89925	16mm O.D.	1		
89924	18mm O.D.	1		
<b>CABLE KIT SEAL COLLET ASSY - Round Fiber</b>				
CHOOSE ONE SIZE DUCT SEAL BELOW FOR BASE WHISPER				
89932	3.0 - 3.8mm	1		
89933	3.8 - 5.0mm	1		
89934	5.0 - 6.4mm	1		
89935	6.4 - 8.5mm	1		
<b>CABLE KIT SEAL COLLET ASSY - Flat Drop for Base unit</b>				
CHOOSE ONE SIZE DUCT SEAL BELOW FOR BASE WHISPER FLAT DROP BASE				
89841	Fujikura 24 ct. Drop	1		
89911	Essex	1		
89951	Corning ROC	1		
89952	Corning SST	1		
89954	Corning ROC Fast Access	1		
89956	Commscope	1		
<b>FLAT DROP COMPONENTS for 89897, 90064 and 89895</b>				
89502	SEAL COMSCOPE TONEABLE 3/PK	1		
89505	SEAL SST/COMSCPE NON-TONE 3/PK	1		
36508	GUIDE SEAL LOWER FAST ACCESS	1		
36509	GUIDE SEAL UPPER FAST ACCESS	1		
37726	SEAL FUJIKURA 24-CT TONE 3/PK	1		
37730	GUIDE SEAL HALF FUJI 24CT DROP	2		
34671	GUIDE SEAL HALF ROC DROP FIBER	2		
36067	BLOCK BEARING DRIVE ROC DROP	2		
37265	INSERT GUIDE INF ROC WHISPER	2		
89506	SEAL CABLE ROC TONEABLE 3/PK	1		
89507	SEAL CABLE ROC NON-TONEBL 3/PK	1		
34059	GUIDE SEAL HALF SST DROP FIBER	2		
36068	BLOCK BEARING DRIVE SST DROP	2		
89504	SEAL CABLE SST TONEABLE 3/PK	1		
03055	BEARING JAF 88500	4		
34258	SCAP M3X8 SKT S/S	2		
34259	SCAP M3X25 SKT S/S	2		
34271	SCAP M2.5X6MM SK SS	2		
36065	ROLLER DRIVE STRAIGHT KNURL	1		
36066	GUIDE INFEED DROP FIBER	1		
36069	SCAP M6X25 SK SS A	2		
89910	BLOWER MICRO FIBER WHISPER	1		

FOR  
CONFIGURING  
BASE FLAT DROP

## Round Cable

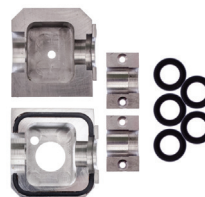

Tube Collet and Clamp Assemblies



Cable Seal Collet Assemblies

## Flat Drop



\* Fast Access uses above cable guide half.

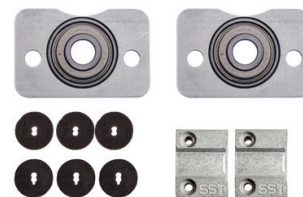

Supplied With All Machines

- Whisper Cable Blowing Machine
- (2) 9V Lithium Batteries
- Toolkit
- Travel bag
- Manual

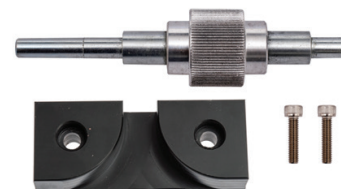

Cable Seal Collet Assemblies

<b>Whisper Round Fiber Part Numbers</b>	<b>Base: 89910</b>
	<b>Plus: 89897</b>

<b>Whisper Flat Drop Fiber Part Numbers</b>	<b>Base: 89915</b>
	<b>Plus: 89895</b>

<b>Whisper Max</b>	<b>Max: 90064</b>
Includes everything for flat drop and round	

Up to 30% savings on accessories when purchasing the Plus or Max

### How To Chose Your WHISPER Component Kits

#### When choosing the Plus Model: (included in price)

Receive all components to blow the 3 most popular sizes round and flat drop

#### When choosing the Max Model: (included in price)

Nothing to pick, you'll receive one of everything for round and flat drop

### How To Chose Your Whisper Flat Drop Component Kits

#### When choosing the Plus Model: (included in price)

Receive all components to blow the 3 most popular sizes

## Gentle Air Blown Fiber Blowing Machine

Now you can depend on the same GMP quality as our larger machines in a new smaller package... The Gentle Air uses compressed air to install the fiber. Coupled with the driven roller is a precision clutch that you can dial in your custom torque from zero to infinity. The rollers, powered by most types of cordless drills (not included), control the blown fiber as it is propelled into the microduct. An electronic monitoring system provides read-outs of speed and distance. The design of the Gentle Air provides for quick and easy component changes for different cable or duct sizes. Its compact size and portable maneuverability make the Gentle Air ideally suited for external or in-building use.

### Main Features:

- Installs cable diameters of 0.039" to 0.118" (1.0 to 3.0mm)
- Digital cable speed and length monitoring
- Accommodates microduct sizes of 4 to 7mm (OD)
- Integral air valve and pressure gauge
- Uses a fully adjustable precision clutch for torque control
- Low maintenance
- Uses most variable speed drills as a power source
- Lightweight, durable construction with precision machined parts
- Travel bag included
- Single person operation

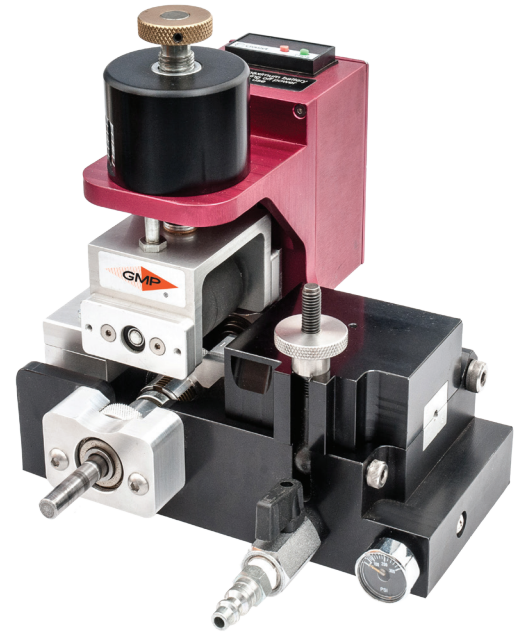

### Specifications:

**Cable Diameter:** 0.039" to 0.118" (1.0 to 3.0mm)  
**Tube Size (Outside Dia):** (OD) 0.158" to 0.275" (4 to 7mm)  
**Cable Speed (Adjustable):** 0-300 ft/min (0-90m/min)  
**Max Air Pressure:** 220 psi (15 Bar)  
**Power Requirement:** Variable Speed Drill  
**Width:** 8.1 in. (206mm)  
**Length:** 9.7 in. (246mm)  
**Height:** 8.5 in. (216mm)  
**Weight:** Approx. (5.4Kgs Approx.)

PLUS

P/N	COMPONENT		
<b>TUBE COLLET AND CLAMP ASSEMBLIES</b>			
<i>CHOOSE ONE SIZE BELOW FOR STANDARD GENTLE AIR</i>			
89918	4mm	1	
89919	5mm	1	
89926	7mm	1	
89927	8mm	1	
89920	8.5mm	1	
<b>CABLE KIT SEAL COLLET ASSY</b>			
<i>CHOOSE ONE SIZE DUCT SEAL BELOW FOR STANDARD GENTLE AIR</i>			
89898	2.0-2.5mm	1	
89899	2.5-3.0mm	1	
89929	1.0-2.0mm	1	

### How To Chose Your Gentle Air Component Kits

**When choosing the Base Model:** (items priced individually)

Pick 1 Tube and collet and clamp assembly

Pick 1 Cable seal collet assembly

**When choosing the Plus Model:** (included in price)

Receive all components to blow the 3 most popular sizes

### Supplied With All Machines

- Gentle Air Cable Blowing Machine
- (2) 9V Lithium Batteries
- Toolkit
- Travel bag
- Manual

**Kit Part Numbers**  
**Base: 89916**  
**Plus: 89901**

Up to 30% savings on accessories when purchasing the Plus

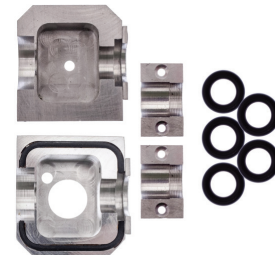

Tube Collet and Clamp Assemblies



Cable Seal Collet Assemblies

## Microdrive Blown Fiber Blowing Machine



### MicroDrive

With the new GMP Micro-Drive, placing Optical fiber couldn't be safer and easier. Built with simplicity and

reliability in mind, this blower is driven by an off-the-shelf battery powered drill. Coupled with the driven roller is a precision clutch which you can dial in to your custom torque settings.

The MicroDrive offers battery powered cable speed and distance counter along with a family of useful accessories.

### Main Features

- Installs cable diameters of 0.142", 0.150", 0.177" (3.6, 3.8, 4.5mm)
- EABF® compatible
- Accommodates microduct sizes of (OD) 0.335", 0.500" (8.5, 12.7mm)
- Uses most any variable speed 3/8" drill as a power source
- Precision magnetic clutch helps to protect your cable
- Light weight, durable construction with precision machined parts
- Single person operation
- Digital cable speed and length monitoring
- Integral air valve and pressure gauge
- Low maintenance
- Ideal for smaller jobs where a bigger machine is simply too much
- Heavy duty hard case included

### Specifications:

Cable Diameter:	0.142", 0.150", 0.177" (3.6, 3.8, 4.5mm)
Tube Size (Outside Dia):	(OD) 0.335", 0.500" (8.5, 12.7mm)
Cable Speed (Adjustable):	0-300 ft/min (0-90m/min)
Max Air Pressure:	220 psi (15 Bar)
Power Requirement:	Variable Speed Drill with adjustable torque
Width:	9.7" (248mm)
Length:	5.6" (143mm)
Height:	6.6" (169mm)
Net Weight:	6 lbs. (3.1kg)

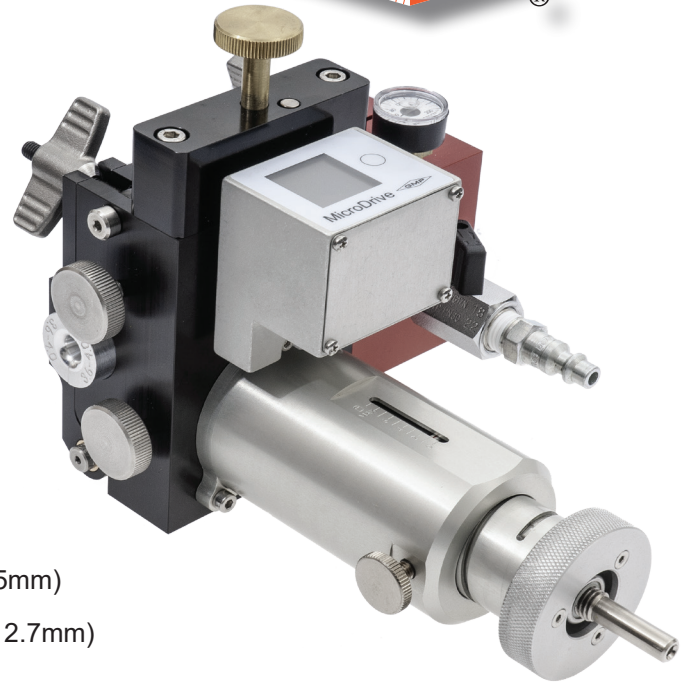

CABLE BLOWING

**Order: P/N 89850**  
MicroDrive Blown Fiber Blowing Machine  
Weight: 6 lbs. (3.1kg)



*Supplied with a durable waterproof crushproof case*



### Air Supply Hose

- Quickly connects to the Whisper via a quick coupling.
- Hose is 12 1/2 feet long for easy setups.
- The flexible hose is abrasion, weather and ozone resistant.
- Inlet connection is a two claw Chicago coupling.

**P/N 89949** Weight: 2 lbs. (.9kg)



### Tripod Mount Kit

- Lightweight and durable
- Positive locking clamps
- Aluminum alloy construction
- Flat Head design
- Easy Setup
- Built in shoulder strap
- Folds for storage
- Max work height 63" (160 cm)

**P/N 89945** Weight: 9 lbs. (4.1kg)



**METAFLUX CHAIN LUBRICANT**

This Chain Lubricant is a fully synthetic, special chain lubricant for use in lubrication of the **Tornado's** drive chain. Can also be used as a superior lubricant on any other machine which uses a chain.

- High penetration, powerful adhesion, no drips
  - Stable viscosity, and no effect on regular O-rings
  - Non-soiling, colorless, free of silicone and solid matter
  - Transparent with corrosion resistance up to one year
  - Long term protection even with high dust occurrency, resistant to hot and cold water
- P/N 89153** Metaflux Chain Lubricant Weight: 13.5 oz. (400ml)



**Polywater® Prelube**

Polywater® Prelube reduces frictional drag during the blowing of outside plant cable into duct. It increases the length of cable that can be blown in a single shot. Prelube can also be used to blow in the hollow microtubes intended to hold future microcables. Over the last decade, Prelube has been proven in the blowing of tens of thousands of kilometers of cable in over 20 countries on a variety of cable blowing machines.

P/N	Description	Weight
Polywater® Prelube 2000™ - Used for Duct		
<b>89141</b>	Polywater® Prelube 2000™ 12 quart case	25 lbs. (11.5kg) per case
<b>89199</b>	Polywater® Prelube 2000™ 5 gallon pail	38 lbs. (17kg) per pail
Polywater® Prelube 5000™ - Used for microduct		
<b>89568</b>	Polywater® Prelube 5000™ 6 8 oz. bottles	6 lbs (2.7kg) per case

**Innerduct Pressurization Test Kit**

The Innerduct Pressurization test kit is used to test the integrity of the duct before the cable is blown in. GMP offers kits for 1 1/4" and for 1 1/2" duct. Each kit comprises of:

- Pressure valve assembly
- Innerduct Seal-Off
- End Plug for sealing the opposite end of the innerduct
- Carry Case
- Seal-offs and End Plugs also available for 1 and 2" duct.



**P/N 89641**

1 1/4" Innerduct Pressurizing Kit  
Weight: 15 lbs. (6.8kg)

**P/N 89642**

1 1/2" Innerduct Pressurizing Kit  
Weight: 17 lbs. (7.7kg)

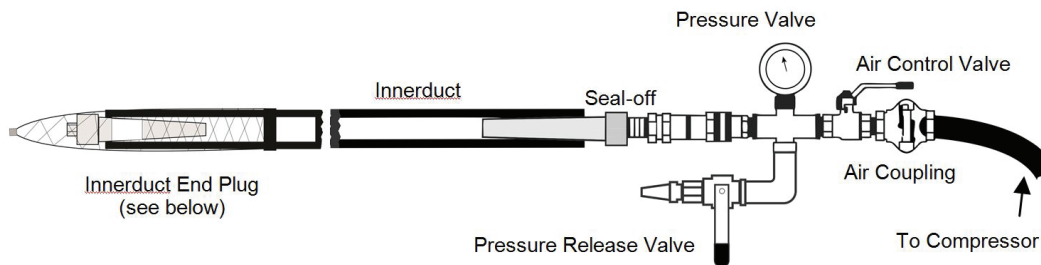

### Innerduct and Conduit Blowing Kits

These kits contain the essentials for blowing 1/4" line thru a 1 1/4" or 1 1/2" innerduct. The major components are a control valve, a 1/4" rope adapter and a 1 1/4" or 1 1/2" innerduct seal-off.

The kit also includes:

- A Chicago fitting for connecting to the air supply.
- A quick disconnect fitting for attachment to the seal-offs
- A solid plug for pressurizing ducts
- A protective carrying case



#### P/N 89815

Blow Gun Kit for 1 1/4" Innerduct  
Weight: 4.6 lbs. (2.1kg)

#### P/N 89817

Blow Gun Kit for 1 1/2" Innerduct  
Weight: 5.9 lbs. (2.7kg)

#### P/N 89816

Blow Gun Kit for 4" Conduit  
Weight: 11.5 lbs. (5.2kg)

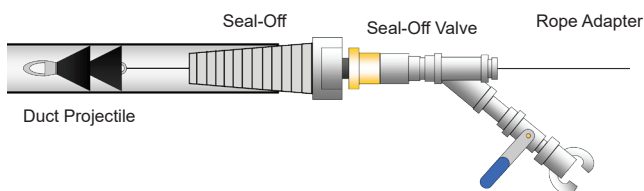

### Seal-off Control Valve

Utilizing a ball valve with a safety locking lever, the Control Valve allows control of air flow. Equipped with a Chicago fitting for connecting to the air supply. Also there's a quick disconnect fitting at the end for attachment of seal-offs. Comes standard with a solid plug in lieu of rope adapter for pressurizing ducts.  
P/N 89801 Weight: 3 lbs. (1.36kg)



### Rope Adapter

Allows for a wide range of rope diameters to be used with the above control valve.

P/N 29448 3/16" (5mm), P/N 29446 1/4" (6mm), P/N 29447 3/8" (10mm)



### Inline Pressure Gauge

Placed inline between the control valve and an innerduct seal-off or conduit seal-off to accurately measure inlet pressures.

P/N 70699 Weight: 1.5 lbs. (.68kg)



### Innerduct Seal-Off

Featuring quick disconnects, these insert into the innerduct and twists tight for seal, utilizing the same Buttress thread as our Pulling Eyes.

P/N	Description
89803	Duct Seal-off 3/4"
89804	Duct Seal-off 1"
89805	Duct Seal-off 1 1/4"
89806	Duct Seal-off 1 1/2"
89807	Duct Seal-off 2"

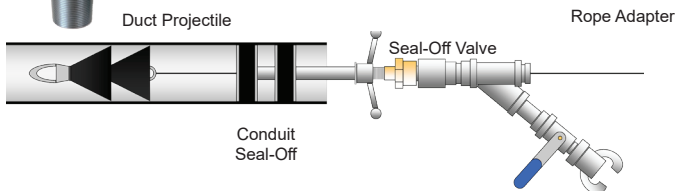

### Conduit Seal-Off

When used with the control valve the conduit seal-offs securely fit into a duct with a turn of the wing-nut handle, expanding the two rubber plugs for a firm seal. 15 psi (1 bar) maximum.

P/N	Description
89808	Conduit Seal-off 2"
89809	Conduit Seal-off 3"
89810	Conduit Seal-off 3 1/2"
89811	Conduit Seal-off 4"
89812	Conduit Seal-off 4 1/2"
89813	Conduit Seal-off 5"



### Foam Line Carriers for conduit

- Cleans water and debris from most conduit
- Durable for indefinite re-use.
- For use with most type of systems

P/N	Desc.
70536	1 1/4"
70537	1 1/2"
70538	2"
70543	5"



### Duct Projectiles for 1 - 5" conduit/innerduct

- Flexible rubber cones are durable for many repeated uses
- Fast and efficient for long runs with easy pullback

P/N	Description	P/N	Description
70505	1" for Duct	70513	2" for Duct
70506	1 1/4" for Duct	70514	2 1/2" for Duct
70508	1 3/8" for Duct	70515	3" for Duct
70509	1 1/2" for Innerduct	70516	4" for Duct
70510	1 1/2" for Duct	70517	5" for Duct



### Parachute Inflatable Carriers for 1 - 2" innerduct

- Used for air-assist pulling through occupied conduits.
- Constructed of high denier nylon for durability.

P/N	Description
89830	Parachute for 1"
89831	Parachute for 1 1/4"
89832	Parachute for 1 1/2"
89833	Parachute for 2"



### Missile Line Carriers for 4" conduit

- Fast blowing and vacuuming of 4" diameter conduit by low-friction plastic carriers.
- Easily removed from conduit if stuck or jammed.

P/N	Description
70529	Missile for 4" conduit





### Longitudinal Duct Slitter

This device is a mechanically-assisted, hand-operated tool designed to make longitudinal slits in long lengths of innerduct.

- Works with innerduct from 1 1/4 - 2".
- Excellent for use with High and Medium Density Polyethylene.
- Ratchet design is safer for both user & cable as compared to sheath knives.
- Can slit from either an open end of innerduct or mid-section.
- Regulated cutter depth control for wall thicknesses .150-.275".
- Comes with a blue leather storage pouch and blade protector.
- User supplies standard 3/8" drive ratchet wrench.

**P/N 10900** Weight: 3 lbs. (1.5kg)

Replacement blade **P/N 10901** Weight: 1 oz. (28g)

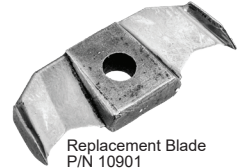

Replacement Blade  
P/N 10901



### Cable Sheath And Duct Slitter

An ingenious tool with a ratcheting design that longitudinally slits the outer sheath of telecom cables or innerduct.

- Works with cable from 1/2 to 4".
- Ratchet design is safer for both user & cable compared to sheath knives.
- Can slit from either an open end or mid-section of cable or duct.
- Regulated cutter depth control eliminates conductor or fiber damage.
- Also effective on microduct.

**P/N 10923** Weight: 2 lbs. 11 oz. (1.2kg)

Replacement Blade **P/N 10901** Weight: 1 oz. (28g)



### ZIDS Duct Slitting Tool

The ZIDS (Zip Inner Duct Slitter) Tool inner duct splitter is the fastest, safest, and handiest device for inner duct splitting currently on the market. Used along with a wood router, our inner duct splitter can cut through pipe walls within seconds and with little effort. Our inner duct splitter is available nationwide via our distributors.

**P/N 70464** Weight: 5 oz. (140g)



### Innerduct Cutter

Make precise cuts around innerduct diameters from 3/8 to 3 3/8" (9 - 88mm)

- Used primarily for allowing access to fiber already placed inside of innerduct when it needs to be repaired, or broken out, the tubing cutters provide a lean cut every time.
- The special wheel allows it to cut a wide variety of plastic pipe and tubing.
- Open the cutter with a push of a button.
- Line up the cutter wheel with your cut-off mark. Push in on the knob to bring the wheel up against duct then turn the knob to penetrate.
- Uses a ball detent pin for quick wheel changes.

**P/N 10912** Weight: 2 lbs. 11 oz. (1.2kg)

Replacement Wheel **P/N 10911** Weight: 1 oz. (28g)



### Scissor Style Innerduct Cutter for 1 inch- Klein Tools® #88912

Cuts 1-Inch (25 mm) O.D. multilayer plastic tubing and up to 3/4-Inch (19 mm) Schedule 40 PVC pipe

- Handle latch keeps tool closed
- PTFE coated steel blade
- Rubberized grip with anti-impact design

**P/N 88912** Weight: 1/2 lb. (.22kg)

Replacement Blade **P/N 88914** Weight 1 oz. (28g)



### Scissor Style Innerduct Cutter for 2 inch- Klein Tools® #50034

Tools ratcheting PCV cutter cuts white and gray 1/2-Inch to 2-1/2-Inch white and gray schedule 40 and 80 PVC. The ratcheting action allows for easy, one-handed cutting and blade release. Lightweight, comfortable handle reduces hand fatigue

**P/N 89564** Weight: 1.3 lb. (.6kg)



### Clear Bodied Push-On Connectors For Microduct

These no-tool connectors make it fast and easy to join two lengths of microduct of the same size. Simple to remove without tools. Sold in packs of 25



Size O.D.	P/N
3mm	70716
4mm	70717
5mm	70718
6mm	70719
7mm	70720

Size O.D.	P/N
8mm	70721
8.5mm	70727
12mm	70723
12.7mm	70724
14mm	70725

Size O.D.	P/N
16mm	70726
18mm	70715

#### Reducer Couplings

Size O.D.	P/N
5mm to 3mm	89711
5mm to 4mm	89712
8.5mm to 8mm	70728
12.7mm to 12mm	70729
22mm to 18mm	70736

### Split Glass Filled Polymer Duct Coupling

The coupler is produced from a glass fiber reinforced nylon resin. The coupler is heat and UV stabilized, and offers excellent impact strength. It's reusable and is ideal for temporarily coupling conduits, particularly at slack-loop locations, and also for air-assisted jetting applications. The coupler is easily assembled using a 7/16" nut driver.



- No special tools required.
- 100% reusable - can install with cable inside.
- Air and water tight.
- Fungus and chemical resistant
- Not recommended for Plow Chute.
- No I.D. reduction

P/N	Nominal Size (SDR)	Duct O.D.	Weight
70692	1"	1.295 - 1.335	9 oz.
70693	1 1/4"	1.640 - 1.680	9 oz.
70694	1 1/2"	1.880 - 1.920	10 oz.
70695	2"	2.355 - 2.395	10 oz.

### Tube Connectors For 22 And 27mm

These are unique push-fit couplers for HDPE micro ducts and are suitable for both blowing and pulling installation methods. The push-fit method ensures easy and simple assembly and disassembly. Sold in packages of 10.



P/N	Description	Weight
70665	Tube Connector 22mm 10/pk	1 lbs. (454kg)
70666	Tube Connector 27mm 10/pk	1 lbs. (454kg)

### Cable Overblowing Junction Box

Available in three sizes, the GMP Cable Overblowing Junction Boxes have been designed to install a new cable or innerduct into an existing occupied 1-1/4 in., 1-1/2 in. and 2 in. innerduct (subject to space being available).

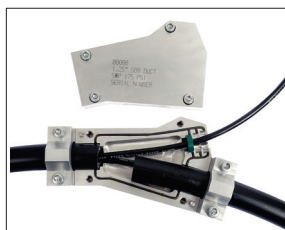

P/N	Description	Weight
P/N 89066	Junction Box 1.25" Duct	9 lbs. (4kg)
P/N 89067	Junction Box 1.50" Duct	9 lbs. (4kg)
P/N 89068	Junction Box 2.00" Duct	11 lbs. (5kg)

### Cable Fleeters

This fleeter replace the manual method of "figure-eighting" cable at the midpoint and provides protection and security for the cable. Following installation of the cable in the first leg of the duct route the balance of the cable is removed from the drum and fed into the fleeter, thereby releasing the cable end ready for blowing into the second leg. The fleeter provides a smooth and simple system while ensuring cable protection from pedestrians or vehicles and prevents contamination from mud, soil or dust.



MICRO FLEETER P/N 89002



TRAILER MOUNTED FLEETER P/N 89012

#### SPECIFICATIONS:

Cable diameter:	5 – 8.5 mm (0.196 – 0.334") OD Max
Cable Length:	6500 Ft. (2000m) of 8.5mm cable
Duct Size:	8 - 18mm ø
Basket Diameter:	47.25" (1200mm)
Max. Width:	50.6" (1825mm)
Height:	55.9" (1420mm)
Weight:	99 lb (45kg)

#### MICRO FLEETER P/N 89002

#### TRAILER MOUNTED FLEETER P/N 89012

1/2" (13mm) Max O.D.
10,000 ft.(3000m) 1/2" (13mm) FOC
Up to 2"
69" (1750mm)
83" (2110mm)
75" (1900mm)
400 lbs. (181kg)

## Sidewinder Fiber Optic Cable Puller

The GMP SideWinder, Trailer Mounted Fiber Optic Puller has been designed to exceed the requirements of installing underground telecommunication cables, employing a 42" diameter single capstan to provide a controlled force to the pulling rope or tape. The single capstan allows the winch to be placed at the mid point of a section to assist in the pull, thus achieving longer pulls.

At 1500 lbs., the unit is easily pulled by a standard pickup truck. The power source is a commercial grade electric start Honda GX390® gasoline engine which drives the fixed displacement tandem mounted hydraulic pumps.

The rope take-up drum is removable and can be split to enable removal of rope. The capstan can be rotated through 90° on a swivel bracket from the in-line working position to the transverse transit position when in tow. When the winch is in the working mode the rear props are extended out of the chassis to provide greater stability.

The Sidewinder has electric start and all essential controls are located together within the operators reach.



### Specifications:

Max. Pulling Capacity:	600 lbs. (272kg)	Hitch Coupling:	Lunette Ring (ball coupler available)
Max. Rope Speed:	262 ft/min (80m/min)	Lighting Adapter:	7-Pole RV Blade (other types available)
Capstan Diameter:	42" (1067mm)	Power Supply:	Honda GX390 12 HP, Recoil Start, Overhead Valve, Cast Iron Cylinder Sleeve, 1.5 Gallon tank Calibrated gauge bezel
Length:	144" (3658mm)	Load indication:	
Overall Width:	69" (1753mm)	Main Drive:	Fixed displacement tandem pumps to fixed displacement high torque motors.
Height:	57" (1450mm)	Gear Box:	In-line planetary gearbox (capstan drive)
Weight:	1500 lbs. (680kg)		
Track:	60" (1676mm)		
Tire Size:	F78-14 205/75D14		

P/N 70751 42" Capstan Sidewinder with electric start

## Ecapstan Electric Fiber Optic Pulling Capstan

Introducing the **ECAPSTAN ELECTRIC FIBER OPTIC PULLING CAPSTAN (71490)** – the ultimate solution for clean, quiet, and efficient cable pulling. Designed to deliver up to **900 lbs of pulling force**, this powerhouse works tirelessly all day on a single charge, pulling up to **15,000 ft of cable** (estimated based on average pull and speed).

### Why Choose the GMP eCapstan?

- **Whisper-Quiet Operation:** Enhance jobsite communication and safety with minimal noise.
- **Eco-Friendly Design:** No engine, no emissions – just pure electric efficiency.
- **Precision Control:** Adjustable pulling force and speed with electronically controlled setpoints from 0-800+ lbs.
- **Effortless Operation:** Quick push-button settings for capstan diameter, max pulling force, and speed.
- **Durable Battery Life:** Over 2000 full charging cycles (5+ years) with safe LiFePO4 technology.
- **Versatile Setup:** Compatible with hitch mounts or ground stands, and supports 32" or 42" capstans.
- **Single-Person Operation:** Simplify your workflow with easy-to-use features.
- **Data Recording:** Monitor pull force during operation for added precision and reliability.

Upgrade your cable-pulling game with the GMP eCapstan – where innovation meets performance. **Clean. Quiet. Powerful. Revolutionize Cable Pulling with the GMP eCapstan!**

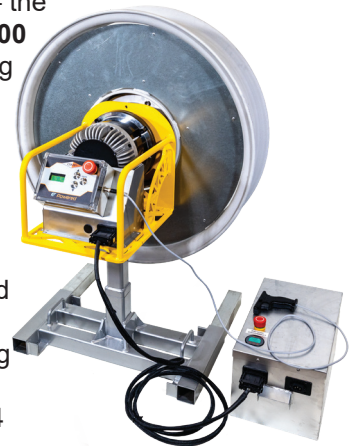

### Specifications

Max Pulling Load: 900 lbs. (3558 N) @ 100lb setpoints  
 Max Pulling Speed: 300 feet/minute (76m/min)  
 Battery Life Max Pull: 8500' @ 600 lbs. & 175 feet/min  
 Battery Type: LiFePO4  
 Battery Size: 48V, 40Ah  
 Charge Time: 8hr

P/N 71490 Ecapstan Fiber Optic Pulling Capstan Weight: 326 lbs. (147kg)



## Hydraulically Limited Cable Puller

The Hydraulically Limited Cable Puller is designed to offer exceptional value while providing critical speed control and overload protection. It is simple to set up and easy to operate. Our Cable Puller has all of the features contractors demand, plus GMP quality and durability that you can rely on . . . year after year.

### Standard Features:

- Adjustable pull control, up to 1000 lbs. (453kg) maximum on a 40" (101cm) diameter capstan.
- Speeds up to 425 ft/min @ 15 gpm flow.
- Control panel with pressure gauge, pressure adjustment knob and directional foot control valve.
- 1/2" (12.7mm) non-spill quick-disconnect fittings for 2500 psi maximum hydraulic source input.



Power Pack  
P/N 70487



Foot Control Valve

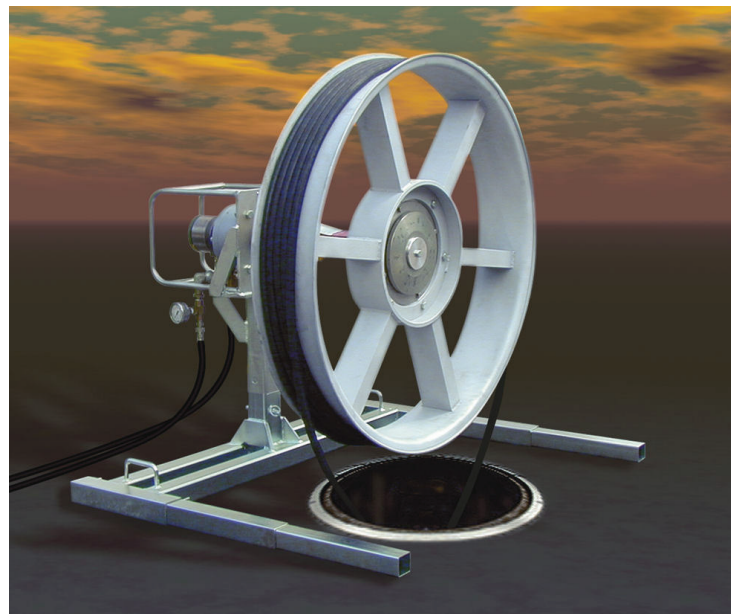

Hydraulically Limited Cable Puller with Mid-Assist Fiber Optic Capstan

### Optional Mounts:



Self Support Frame  
P/N 31116



Receiver Mount  
P/N 31219



Socket Mount  
P/N 70250 and 70249

### Mid-Assist Fo Capstans

P/N	Description	Weight
15470	25"	96 lbs. (44kg)
70472	32"	112 lbs. (51kg)
70474	42"	110 lbs. (50kg)

P/N	Description	Weight
70483	Hydraulically Limited Cable Puller Motor with Self-Support Frame, Foot Control Valve and (2) hydraulic hoses. Capstan sold separately.	293 lbs. (133kg)
70484	Hydraulically Limited Cable Puller Motor with Vehicle Receiver Mount, Support Jack, Foot Control Valve and (2) hydraulic hoses. Capstan sold separately.	248 lbs. (113kg)
70486	Hydraulically Limited Cable Puller Motor with Foot Control Valve and (2) hydraulic hoses for 2 1/2" Square Socket Mount. Capstan sold separately.	200 lbs. (91kg)



## Mid-Assist Fiber Optic Slip Clutch Capstan

GMP offers you a choice of several lightweight aluminum alloy units that mount on a standard 2 7/16" (62mm) diameter drive shaft with either a bayonet or a cross pin type of connection.

P/N	Working Dia.	Working Width	Pull	Weight
15472	25" (635mm)	5" (127mm)	600 lbs. (2669 N)	80 lbs. (34kg)
15479	25" (635mm)	5" (127mm)	1000 lbs. (4448 N)	100 lbs. (45kg)
15470	25" (635mm)	5" (127mm)	n/a*	86 lbs. (39kg)
70351	32" (813mm)	7.5" (190mm)	600 lbs. (2669 N)	80 lbs. (37kg)
70381	32" (813mm)	7.5" (190mm)	750 lbs. (3336 N)	80 lbs. (37kg)
70471	32" (813mm)	7.5" (190mm)	1000 lbs. (4448 N)	80 lbs. (37kg)
70472	32" (813mm)	7.5" (190mm)	n/a*	86 lbs. (39kg)
71470	42" (1067mm)	7.5" (190mm)	550 lbs. (2446 N)	135 lbs. (61kg)
70471	42" (1067mm)	7.5" (190mm)	600 lbs. (2669 N)	135 lbs. (61kg)
70472	42" (1067mm)	7.5" (190mm)	1000 lbs. (4448 N)	135 lbs. (61kg)
70474	42" (1067mm)	7.5" (190mm)	n/a*	100 lbs. (45kg)

\* = Custom settings as required by user



## Continuous Duct Rodders

GMP produces the best performing and most durable duct rodders available anywhere - at a price that represents the very best value. Decades of in-field use have proven this high visibility, orange rod material to have the ideal combination of the mechanical properties of tensile strength, modulus, stiffness and bending behavior.

- These duct rodders are essential tools for underground tasks such as cleaning and locating ducts, threading lines or pulling cables.
- Rodders come equipped with a male threaded end fitting and tapered head on the leading end and a female threaded fitting on the back end.
- Our carriers are made of tubular steel and are powder coated for corrosion resistance. Larger diameter carriers have inboard wheels for easy transport at the job site. Each carrier is fitted with a hand-operated brake to control payout.
- Available in standard or toneable rod.

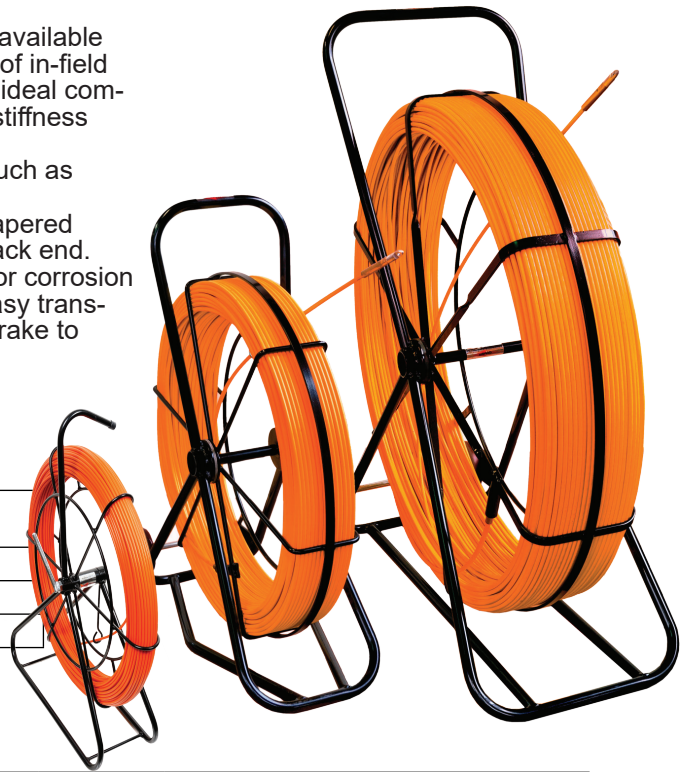

### SPECIFICATIONS

Nominal Size	End Threads	Rated Pull strength	Min Bend Radius
1/4" (6.7mm)	5/16-18	500 lbs.-f (2.2kN)	7.4" (188mm)
3/8" (9mm)	3/8-16	1400 lbs.-f (6.2kN)	9" (230mm)
1/2" (12mm)	3/8-16	1800 lbs.-f (8.0kN)	18" (450mm)

### ORDERING INFORMATION

P/N	P/N	Duct Rodder Sizes	P/N	P/N	Duct Rodder Sizes
Std. Rod	Tonable		Std. Rod	Tonable	
89202	N/A	1/4" (6.7mm) X 100 ft (30m)	89244	N/A	3/8" (9mm) X 1400 ft (427m)
89204	N/A	1/4" (6.7mm) X 200 ft (61m)	89245	N/A	3/8" (9mm) X 1500 ft (457m)
89206	N/A	1/4" (6.7mm) X 300 ft (91m)	89246	N/A	3/8" (9mm) X 1600 ft (488m)
89208	N/A	1/4" (6.7mm) X 400 ft (122m)	89247	N/A	3/8" (9mm) X 1700 ft (518m)
89210	N/A	1/4" (6.7mm) X 500 ft (152m)	89248	N/A	3/8" (9mm) X 1800 ft (549m)
89222	88222	3/8" (9mm) X 200 ft (61m)	89249	N/A	3/8" (9mm) X 2000 ft (610m)
89224	88224	3/8" (9mm) X 300 ft (91m)	89252	88252	1/2" (12mm) X 200 ft (61m)
89226	88226	3/8" (9mm) X 400 ft (122m)	89254	88254	1/2" (12mm) X 300 ft (91m)
89228	88228	3/8" (9mm) X 500 ft (152m)	89256	88256	1/2" (12mm) X 400 ft (122m)
89230	88230	3/8" (9mm) X 600 ft (183m)	89258	88258	1/2" (12mm) X 500 ft (152m)
89232	88232	3/8" (9mm) X 700 ft (213m)	89260	88260	1/2" (12mm) X 600 ft (183m)
89234	88234	3/8" (9mm) X 800 ft (244m)	89262	88262	1/2" (12mm) X 700 ft (213m)
89236	88236	3/8" (9mm) X 900 ft (274m)	89264	88264	1/2" (12mm) X 800 ft (244m)
89238	88238	3/8" (9mm) X 1000 ft (305m)	89266	88266	1/2" (12mm) X 900 ft (274m)
89240	N/A	3/8" (9mm) X 1100 ft (335m)	89268	88268	1/2" (12mm) X 1000 ft (305m)
89242	N/A	3/8" (9mm) X 1200 ft (366m)	89270	88270	1/2" (12mm) X 1100 ft (335m)
89243	N/A	3/8" (9mm) X 1300 ft (396m)	89272	88272	1/2" (12mm) X 1200 ft (366m)

### Roller Guide for 3/8" (9mm) & 1/2" (12mm) Duct Rodders

The Roller Guide helps guide the duct rod around bends, sweeps and duct misalignments. Can also be used where a duct is already occupied with a cable. 2 1/4" wide.

**P/N 89360** Wt. 7.36 oz. (.21kg)



### Flexible Leader

The Flexible Leader is another tool used to guide the duct rod around bends, sweeps and duct misalignments.

**P/N 89371** 1/4" (6.7mm) Wt. 1 oz. (.03kg)

**P/N 89370** 3/8" (9mm) & 1/2" (12mm) Wt. 2.24 oz. (.06kg)



### Shackle Fitting

3/8" (9mm) & 1/2" (12mm) Shackle

Fitting is used with our Tapered Heads to provide a larger pulling loop for attaching the pulling line or rope.

**P/N 09339** Wt. .80 oz. (.02kg)



### Swivel Coupling

The Swivel Couplings connect two duct rods when one length of duct rod is not long enough for the full conduit run. Also provides a rotating swivel when pulling line, wire or rope.

**P/N 89380** 1/4" (6.7mm)

Wt. .48 oz. (.01kg)

**P/N 89382** 3/8" (9mm) & 1/2" (12mm)

Wt. 4.32 oz. (.12kg)



### Tapered Heads

**P/N 89350** 1/4" (6.7mm) Wt. .16 oz. (.01kg)

**P/N 89352** 3/8" (9mm) & 1/2" (12mm) Wt. .48 oz. (.12kg)



### Sonde Adapters

**P/N 89384** Male 1/4" x 20 Wt. 2.08 oz. (.06kg)

**P/N 89394** Female M10 x 1.5 Wt. 1.76 oz. (.05kg)

*Sonde adapters will only work with 3/8" (9mm) and 1/2" (12mm) duct rodgers. Other adapters are available upon request.*



### Sonde

The sonde is a small self-contained transmitter that connects to the end of the duct rod. The sonde will help trace the duct route and can also locate duct blockages or collapses

**P/N 88283**

Weight: 3 oz. (.1kg)



### Sonde Missile Kit

The sonde missile safely carries the Sonde **P/N 88283** through a duct with compressed air in order to test the integrity of a duct or precisely locate a blockage. Sonde sold separately.

**P/N 89396** 1" Duct - SDR 9, 11, 13.5, 15.5, 17

**P/N 88285** 1 1/4" Duct - SDR 9, 11

**P/N 88286** 1 1/4" Duct - SDR 13.5, 15.5, 17

1 1/2" Duct - SDR 9

**P/N 88287** 1 1/2" Duct - SDR 11, 13.5, 15.5

**P/N 88288** 2" Duct - SDR 9, 11, 13.5, 15.5



### Male & Female Fitting Repair Kits

Used as a replacement if the end fittings break off. Epoxy and installation instructions included.



Std. Rod	Toneable	Description	Wt.
<b>89411</b>	N/A	1/4" (6.7mm) Male	.48 oz. (.01kg)
<b>89412</b>	N/A	1/4" (6.7mm) Female	.48 oz. (.01kg)
<b>89413</b>	<b>88413</b>	3/8" (9mm) Male	3.96 oz. (.11kg)
<b>89414</b>	<b>88414</b>	3/8" (9mm) Female	4.46 oz. (.13kg)
<b>89415</b>	<b>88415</b>	1/2" (12mm) Male	2.97 oz. (.08kg)
<b>89416</b>	<b>88416</b>	1/2" (12mm) Female	3.47 oz. (.10kg)
<b>89398</b>	<b>89398</b>	Epoxy	2 oz. (.06kg)

### Splice Kit

Includes Epoxy, sandpaper, an inline splice and instructions to repair broken Duct Rodders.



Std. Rod	Toneable	Description	Wt.
<b>89417</b>	N/A	1/4" (6.7mm)	1.76 oz. (.05kg)
<b>89418</b>	<b>88418</b>	3/8" (9mm)	2.88 oz. (.08kg)
<b>89419</b>	<b>88419</b>	1/2" (12mm)	2.40 oz. (.07kg)

### Duct Rodder Accessory Kits

These kits come complete with the everyday essentials you'll need for your rodding. Easily attached to the frame with UV treated tie wraps, the Cordura Nylon pouch has plenty of room to store your accessories and keep them with the rodder where they belong.

**P/N 89424**

Kit for 1/4"

**P/N 89425**

Kit for 3/8"

**P/N 89426**

Kit for 1/2"



### Traceable Rod Detection

GMP offers a complete rod detection system along with a 33 khz Sonde for use on our traceable 3/8" and 1/2" rodgers. Call for details.

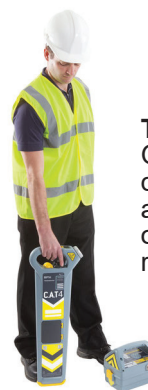

## Powered Duct Rod Pusher

With GMP's Powered Duct Rod Pusher and a 1/2" GMP Duct Rodder, the job of placing pulling lines or fiber cables in old or occupied conduits just got that much easier with less personnel.

- Hydraulically powers GMP 1/2" Duct Rodders in to and out of conduits.
- Pushes and pulls with forces up to 300 lbs.
- Rod speeds up to 130'/min (40m/min)
- Accurately measures footage and speed with an electronic monitoring system that works in either direction. The readout can be scaled to feet or meters.
- When pulling back, the fiberglass rod is placed directly back onto the cassette.
- Features rod access areas for wiping the rod clean during the pull back operation. Also comes with a package of rod wiper pads (P/N 32290)
- Duct Clamp on the machine, and the specially designed Duct Mounting Clamp Assembly (P/N 32221) provided on the rodder cassette, help stabilize both pieces of equipment during use.
- Comes with a gasoline driven power pack and hoses.
- Pusher is mounted on a lightweight, brightly painted, tubular-steel frame that can be tilted at a 30-degree angle to the manhole to reduce initial bending of the fiberglass rod.
- Must order 1/2" Duct Rodder Separately. Also, user must provide length of 1 1/4" innerduct between Rod Pusher and Rodder Cassette, and another length of 1 1/4" innerduct between the pusher and the duct to be rodded.



*Supplied with gas powered hydraulic power pack*



### SPECIFICATIONS:

- Capacity:** 1000' x 1/2" (12.7mm) fiberglass rod  
**Speed:** Up to 130'/min (40m/min)  
**Force:** Pushes and pulls with forces up to 300 lbs. (136kg)  
**Drive:** Dual hydraulic motor tractor belt drive  
**Controls:** Emergency stop switch, power on/off button, hydraulic on/off control valve, hydraulic pressure display gauge, directional lever, speed control, speed and distance indicator  
**Height:** 39" (99cm) **Length:** 42" (107cm) **Width:** 27" (69cm) **Weight:** 210 lbs. (95kg)

P/N	Description Package	Weight
89004	Powered Duct Rod Pusher (calibration in feet)	210 lbs. (95kg)
89005	Powered Duct Rod Pusher (calibration in meters)	210 lbs. (95kg)

## eRodder Battery Powered Duct Rod Pusher

Experience unmatched efficiency and convenience with the GMP eRodder, powered by DEWALT FLEXVOLT® battery technology. Designed for quiet, emission-free operation, this innovative tool delivers 180 lbs of force at an impressive 125 feet per minute. Perfect for professionals, it offers:

- **Variable Speed Control:** Operate with precision using the remote hand control or optional foot control.
- **Ultimate Maneuverability:** Mounted on a three-wheel cart with airless off-road tires and a foldable handle for easy transport.
- **Enhanced Safety:** Quiet operation improves jobsite communication, while the rod distance counter and duct clamps ensure accuracy and stability.
- **One-Man Operation:** Simplify your workflow with a tool designed for efficiency and ease.

With a rod capacity of 3/16 – 7/8 inch (6.3 – 22.2mm), two wheel brakes, and proven DEWALT battery technology, the eRodder is your go-to solution for duct rod pushing. Say goodbye to engines and emissions—upgrade to the future of duct rod pushing today!



### Specifications

- Max Pushing Load: 180lbs. (800 N)  
 Max Pushing Speed: 125 feet/minute (38m/min)  
 Battery Life Max Pull: 8500' @ 600 lbs. & 175 feet/min  
 Battery Type: DEWALT FLEXVOLT® 12.0 Ah Battery (DCB612)  
 Height: 44 in (1118mm)      Width: 26 in (660mm)  
 Height Folded: 30 in (762mm)      Weight: 80 lbs. (36kg)  
 Length: 52 in (1321mm)



*optional foot control  
P/N 71800*

P/N	Description Package	Weight
77000	eRodder Duct Rod Pusher	80 lbs. (36kg)
71800	Optional Foot Control	19 lbs (8.6kg)



### Cable Pulling Harnesses

This convenient product will allow multiple pulls at one time by attaching 2 to 4 cables or ducts to the Puller.

- The slings are manufactured from aircraft quality wire rope.
- The various legs are staggered in length so the individual connections are not interfering with each other. The lead coupler can be easily dismantled to change out a leg or to add another leg.
- Each leg is marked with load capacity and they are pull tested to 3 times that rating. The safety factor of 3:1 is based on equal pull on all cables, (horizontal pull only).
- Other sling configurations are available upon request.

P/N	Number of Legs	Maximum Harness Width	Safe Working Load (3:1)	Wire Rope Diameter	Leg Lengths
70298	3	2 1/4" (57mm)	2000 lbs. (9kN)	1/8" (3mm)	7", 10", 15"
70299	3	3 1/8" (79mm)	5800 lbs. (26kN)	1/4" (6mm)	10", 18", 26"
70300	3	3 1/2" (89mm)	8400 lbs. (37kN)	3/8" (10mm)	16", 25", 36"
70312	4	2 1/4" (57mm)	2000 lbs. (9kN)	1/8" (3mm)	7", 10", 15", 19"
70313	4	3 1/8" (79mm)	5800 lbs. (26kN)	1/4" (6mm)	10", 18", 26", 35"
70314	4	3 1/2" (89mm)	2000 lbs. (9kN)	3/8" (10mm)	16", 25", 36", 48"

### Break-away Swivels

Our Break-away Swivels give you invaluable protection when pulling either fiber optic or coaxial cable.

- These simple tools provide an inexpensive fracture point between the pulling line and cable avoiding costly cable damage if the cable's rated pulling capacity is exceeded.
- The swivels are available in two diameters; 7/8" (22.23mm) made from high quality aluminum and 5/8" (15.88mm) made from steel.
- The 5/8" size is extremely convenient when working with inner-duct sizes below 1 5/8" in diameter.
- The design of the swivels incorporates a replaceable tension bolt that joins the barrel eye and swivel body. The bolt separates when pulling loads on the cable reach +/-5%. The damaged bolt can then be replaced in seconds using the Allen wrench (included) and screwdriver.



### 5/8 Break Away Swivel

Break Point	Color Code	P/N Swivel	P/N Repl Bolt
200 lbs. (91kg)	Orange/White	71399	26309
220 lbs. (100kg)	Red/White	71400	26310
295 lbs. (134kg)	Green/White	71401	26305
340 lbs. (154kg)	White	71402	30333
400 lbs. (181kg)	Blue/White	71403	26306
420 lbs. (190kg)	Yellow/White	71404	26307
435 lbs. (197kg)	Violet/White	71405	26308
450 lbs. (204kg)	Orange	71406	25494
500 lbs. (226kg)	Violet	70188	26325
600 lbs. (272kg)	Yellow	71408	25493
700 lbs. (317kg)	Brown	70191	26326

### 7/8 Break Away Swivel

Break Point	Color Code	P/N Swivel	P/N Repl Bolt
340 lbs. (154kg)	White	53700	30332
450 lbs. (204kg)	Orange	53701	34786
600 lbs. (272kg)	Yellow	53702	34341
800 lbs. (364kg)	Blue	53703	34342
1,000 lbs. (454kg)	Green	53704	34343
1,200 lbs. (544kg)	Red	53705	34344

### Flexible Pulling Grips

Pulling Grips, sometimes referred to as pulling socks or stockings, are indispensable in many different cable pulling applications. Manufactured from high-tensile, galvanized steel wire that is evenly hand woven in a single, double or triple wire weave according to pulling tension requirements. We reverse weave our grips which create a loop at the end of the grip instead of being crimped or soldered together. The wire is then joined under the crimped head. This creates a higher quality product that outlasts the competition.



#### Single Weave

P/N	Diameter Range	Min. Breaking	Grip Length
70660	.24-.51" (6-13mm)	1984 lbs. (900kg)	11.81" (300mm)
70661	.47-.75" (12-19mm)	3505 lbs. (1590kg)	21.65" (550mm)
70662	.75-.98" (19-25mm)	4674 lbs. (2120kg)	23.62" (600mm)
70663	.98-1.5" (25-38mm)	5644 lbs. (2560kg)	27.56" (700mm)

#### Double Weave

P/N	Diameter Range	Min. Breaking	Grip Length
70670	.39-.79" (10-20mm)	4101 lbs. (1860kg)	23.62" (600mm)
70671	.79-1.18" (20-30mm)	4974 lbs. (2256kg)	23.62" (600mm)
70672	1.18-1.57" (30-40mm)	8148 lbs. (3696kg)	23.62" (600mm)
70673	1.57-1.97" (40-50mm)	12103 lbs. (5490kg)	23.62" (600mm)
70674	1.97-2.56" (50-65mm)	12103 lbs. (5490kg)	23.62" (600mm)
70675	2.56-3.15" (65-80mm)	16138 lbs. (7320kg)	23.62" (600mm)
70676	3.15-3.74" (80-95mm)	16138 lbs. (7320kg)	23.62" (600mm)

### Non-Metallic Cable Pulling Grips

These flexible nylon mesh pulling grips are for pulling bundled or non-bundled wire and cable. The grips easily slide onto cable bundles and provide a super strong grip when pulled with tension.

- Rated 700 lbs. WLL
- 55 inches long
- **PN 70688** – 3 Pack small grips, green grip for 3/8 to 3/4 inch fiber optic cable
- **PN 70689** – 3 Pack large grips, red grip for 3/4 to 1-3/8 inch fiber optic cable
- **PN 70708** – 6 Pack, 3 small grips, green grip for 3/8 to 3/4 inch and 3 large grips, red grip for 3/4 to 1-3/8 inch



### Ball Bearing Swivels

These tough swivels are designed to handle higher thrust loads for extra cable safety and faster straight pulls.

- Precision-machined body is made of high quality stainless steel with higher working load ratings than comparably sized swivels available on the market.
- These heavy-duty swivels are built with a thrust bearing for tensile load and a radial bearing for bending load.
- Working Load Limit for underground applications is based on a horizontal pull of 3:1 while aerial applications have a WLL of 5:1.

#### Ball Bearing Swivels

P/N Hex Screw	P/N Slotted Screw	Working Load Limit Under Ground lbs. (kN)	Working Load Limit Aerial lbs. (kN)	Eye Width in (mm)	Dia in (mm)	Length in (mm)	Weight lbs. (kg)
71136	70136	2250 (10.0)	1350 (6.0)	3/8 (9.5)	7/8 (22)	3 3/8 (86)	.45 (.20)
71137	70137	5000 (22.2)	3000 (13.3)	17/32 (13.5)	1 1/4 (31.8)	4 5/32 (105.6)	.95 (.43)
70138	71138	7000 (31.1)	4200 (18.7)	9/16 (14.3)	1 3/8 (34.9)	4 19/32 (116.7)	1.35 (.61)
70139	-----	10000 (44.5)	6000 (26.7)	11/16 (17.5)	1 5/8 (41.3)	5 7/16 (138.1)	2.2 (1.00)
70140	-----	25000 (111.2)	15000 (66.7)	1 1/32 (26)	2 1/2 (63.5)	9 5/8 (244.5)	7.6 (3.45)



Fixed

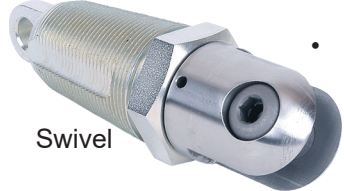

Swivel

### Innerduct Pulling Eyes

These rugged zinc-plated steel pulling eyes allow innerduct placement to become a faster, safer operation.

- Easy insertion by rotating the pulling eye into the innerduct allows the threads to make the connection.
- A convenient hole in the threaded end of the pulling eye body is used to tie off the innerduct pulling line or tape keeping it from being lost during the pulling operation.
- Our Swiveling Innerduct Pulling Eyes eliminate the need to use a separate swivel between the winch line and innerduct.
- The hex portion of the Swiveling Innerduct Pulling Eye allows use of a wrench to make the final turns when inserting into innerduct.

#### Innerduct Pulling Eyes

P/N Fixed	P/N Swivel	Nominal Duct Dia	Max Duct Dia
60510	61510	1" & 1 1/8" (25.4-30.0mm)	1.50" (38.1mm)
60512	61512	1 1/4" & 1-3/8" (31.8 - 35.1mm)	1.75" (44.4mm)
60515	61515	1 1/2" (38.1mm)	2.00" (50.8mm)
60520	61520	2" (50.8mm)	2.50" (63.5mm)

### Microduct Pulling Eyes

These rugged stainless steel pulling eyes allow microduct placement to become a faster, safer operation.

- Easy insertion by rotating the pulling eye into the microduct allows the buttress threads to make the connection
- Each unit is supplied with a galvanized steel lanyard. Three lengths are available.
- Use pulling eyes with different lanyard lengths for staggard pulling multiple ducts at once
- Lanyard's eyelet acts as a built in installation tool



#### Microduct Pulling Eyes

P/N	Description	Length
70800	5-9mm	8"
70801	5-9mm	12"
70802	5-9mm	16"

P/N	Description	Length
70805	10-12mm	8"
70806	10-12mm	12"
70807	10-12mm	16"

P/N	Description	Length
70810	13-15mm	8"
70811	13-15mm	12"
70812	13-15mm	16"

### Strand Pullers & Haven's Grips

Used when pulling and tensioning suspension strand. Strand pullers come equipped with a safety chain in the event the grip accidentally disengages. Haven's grips are used when light, compact grip is desired, and where conductor damage is not a factor.

P/N	Description	Strand Size (mm)	Pulling Load (kgs)	Weight (kgs)
68490	B Strand Puller	Figure-8 Poly Jacket 1/4" (6)	5000 lbs. (2268)	6.7 lbs. (3)
68491	H Strand Puller	3/8" - 1/2" (9.5 - 12.7)	10000 lbs. (4535)	15.5 lbs. (7)
69494	Chicago Grip	Bare Wire .08" - .2" (2-5.1)	1500 lbs. (680)	1.5 lbs. (.7)
68493	Haven's Grip	3/8" - 7/8" (9.7 - 22.4)	8000 lbs. (3636)	4 lbs. (1.8)
68495	EHS Strand Puller	0.22" - 0.55" (5.5 to 13.9)	8000 lbs. (3636)	4 lbs. (1.8)



Chicago Grip



Haven's Grip

## Rope To Rope/Swivel Connectors

### Rope to Rope Connector

- This connector is used to connect two ropes of up to 7/8" (22mm) diameter.
- Rated @ 15,000 lbs. (6804kg) max. load, this connector is made entirely from Stainless Steel.
- Safety factor for load is 3:1 (horizontal pull only).

### Rope to Swivel Connectors

- These Stainless Steel connectors maximize usefulness by catering to the same rope capacity and using different ends to attach to the most popular swivel sizes.
- The sheaves run on clevis pins which are also available as spares.
- Safety factor for load is 3:1 (horizontal pull only).



### Rope to Rope/Swivel Connectors

P/N	Description	Working Load Limit 3:1 Safety Factor lbs. (kN)	Dia in (mm)	Length in (mm)	Weight lbs. (kg)
71130	Rope to Rope Connector	15,000 (66.7)	2 (50.8)	5 1/2 (140)	2.7 (1.2)
71131	Rope to Swivel Connector 1/2"	7,000 (31.1)	2 (50.8)	5 5/16 (135)	2.1 (.95)
71132	Rope to Swivel Connector 21/32"	15,000 (66.7)	2 (50.8)	5 3/8 (137)	2.3 (1.04)

## B Connecting Link

These time-tested, split "sister hooks" or "figure-8" links let you join two pulling lines together, and consist of two E-shaped, forged steel parts held together with a metal pin. Swivel the two halves open to insert the looped end of the each pulling line, then close and secure the link with a few turns of 2" friction tape around the center.



### B Connecting Links

P/N	SIZE	SAFE WORKING LOAD	WEIGHT
80771	1/4"	1000 lbs. (453kg)	.1 lb. (.02kg)
80773	3/8"	1500 lbs. (680kg)	.3 lb. (.08kg)
80775	1/2"	3000 lbs. (1359kg)	.5 lb. (.25kg)
80777	3/4"	6000 lbs. (2718kg)	1.5 lbs. (.75kg)
80779	1"	15000 lbs. (6795kg)	3.0 lbs. (1.5kg)

## 1 1/2 Ton And 3 Ton Manually Lever Operated Link Chain Hoists

- R-CH Series hoists feature a time tested and field proven ratchet & pawl design for transmission and distribution applications
- Light weight, compact design that is simple and easy to operate
- Minimal head and face room are required for operation
- The high strength cast steel alloy construction will provide unmatched resistance to shock and fatigue
- Hoist may be rigged for use in lifting, pulling or binding applications from any position
- Safety hooks rotate 360 degrees and feature spring latches to provide secure support and load connections
- 5 Foot Standard lift
- Manufactured to meet or exceed ASME B30.21

P/N 87268 1 1/2 Ton Weight: 15.25 lbs. (6.9kg)

P/N 87269 3 Ton Weight: 21.25 lbs. (9.6kg)



## J2 Cable Lasher

The Model J2 Cable Lasher is used to lash a single aerial cable or numerous cables to a supporting strand or to an existing lashed cable with stainless steel lashing wire.

- Will lash any single or multiple aerial cables up to 3" (76mm) diameter across on any suspension strand from 1/4" (6mm) to 7/16" (11mm).
- A factory modification will allow the lasher to accommodate 1/2" (12.7mm) strand if necessary.
- Each of two recessed magazines will hold a 1200 ft coil of .045" (365m of 1.1mm wire) lashing wire (or 450 ft of .065"). The Lashing Wire is fully recessed and covered by a gate.
- J2 Lashers make over-lashing easy. Just push down on the strand roller knob, rotate it a quarter turn and you can lash additional cables together on previously lashed cable
- Positive internal gear to gear mechanism has no chains or belts to stretch, slip or break
- Constructed with heat-treated, plated steel, stainless steel, brass and aluminum components. Contains sealed and oil-less bearings to minimize maintenance and assure durability.
- The lasher is furnished with a rugged lightweight storage chest with corrosion resistant hardware, recessed latches and a moisture-proof, tongue-in-groove design for maximum protection when not in use.
- The Lasher is furnished with a 6 ft (1.6m) bridle rope with snap hooks, and an instruction manual.



### Ordering Information

P/N	Description	Package Weight
86070	J2 Cable Lasher	46 lbs. (20.9kg)
86074	J2B Cable Lasher*	46 lbs. (20.9kg)

*\*J2B does not have a strand lock and is relieved for overlashing*

## C2 Cable Lasher

Our compact Model C2 Cable Lasher is perfect for lashing smaller diameter aerial cables to supporting strand with stainless steel lashing wire. The new design improvements make the C2 equally suited for new construction or overlashing up to its full 1 7/8" bundle capacity.

- Lashes single or bundled cables up to 1 7/8" (46mm) onto strand sizes 1/4" to 3/8" (6-10mm) diameter.
- New style strand lock swings out of the way for unobstructed overlashing.
- Simple wire routing yields either "normal" or "loose" wire tension.
- Dual wire magazines for loading two coils of stainless steel lashing wire.
- Typical wire dimensions: 1200 ft x .045" (365m x 1.1mm) or 1600 ft x .038" (487m x 1mm)
- Lightweight and compact: Unloaded weight 35 lbs. (16kg); only 10" O.D. x 18.5" long (25 x 47cm). The C2's tapered housing eases passage through treed areas.
- The C2 Cable Lasher is furnished with a 6 ft (1.6m) bridle rope with snap hooks, an instruction manual and a rugged, lightweight storage chest.
- Like all GMP lashers, the C2 is built to last for many years of service.
- Components are CNC machined from alloy steel, stainless, bronze and aluminum castings to exacting tolerances and treated to withstand corrosion. Gear drives and sealed bearings assure maximum durability with minimal maintenance.

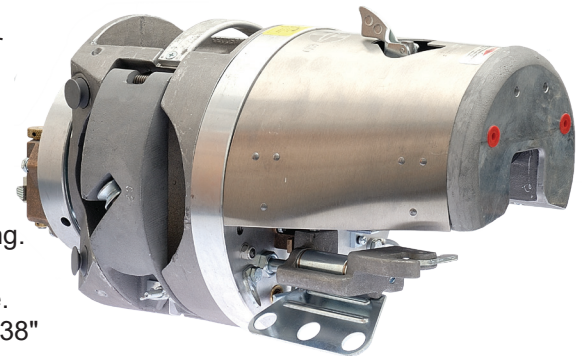

### Ordering Information

P/N	Description	Package Weight
71422	C2 Cable Lasher	35 lbs. (15.9kgs)



## Parallel Pull Accessory

- Enables your J2 or C2 lasher to be operated with parallel pull functionality
- Increases down force to navigate over obstacles and through trees

### Ordering Information

P/N	Description	Package Weight
70467	Parallel Pull Accessory	16 lbs. (7.2kgs)



## Apollo Cable Lasher

Perfect for all telcom cable construction, including Coaxial and FTTx cable. With its light weight and parallel-pull capability, you'll string cable quickly and easily, over all outside plant cable routes. No other lasher or cable spinner will give you all of these advanced features and operating benefits:

- Under 39 lbs., (17.7kg) without wire, 12 1/2" (318mm) diameter
- Lashes any telecom cable/innerduct combination up to 4" (10cm) diameter
- Parallel-pull capability overcomes all terrain obstacles
- Interference-free over-lashing with no modifications
- Positive slip-free gear drive (no belts) tested in excess of 1 million cycles
- Lashes to strand sizes 1/4 to 3/8" (6 -10mm) diameter
- Holds two coils of industry standard wire .045" x 1200 ft (1.1mm x 365 m) or .038" x 1600 ft (1mm x 488m)
- Provides adjustable tension of lashing wire, affording tight or loose lash
- Wire tension constant regardless of amount on spool
- No lasher back-roll when pulling force removed. Front rollers guide cables through the machine
- All smooth edges throughout provide 360° protection against cable damage
- Manual clutch release allows speedy span transfers
- Each Apollo lasher also includes a 6 ft (2m) towing bridle and a rugged, weather-tight storage chest to securely protect your lasher investment while it's not in use and an instruction manual.

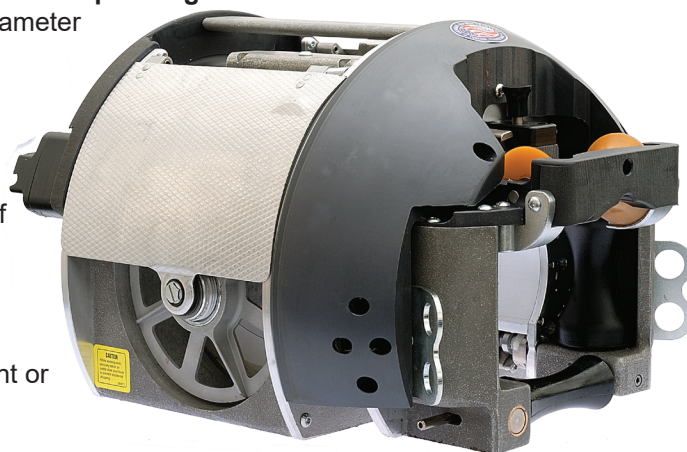

### Ordering Information

P/N	Description	Package Weight
70400	Apollo Cable Lasher	47 lbs. (21.3kg)

## Civitella Cable Lasher

The Civitella cable lasher has been designed to string cable quickly and easily with its light weight and parallel-pull capability. It can be used for new installs or with existing cables in place.

- Max Bundle Size: 2.2 in. (56mm)
- Strand Size: 1/4 - 1/2 in. 6.6M, 5/16M, 10M
- Drive: Parallel Pull Wire Drive
- Wire Size: .038, .045 Stainless
- Coil Capacity: 1 or 2 depending on whether single or double lashing

### Main Features

- Lashes single or bundled cables up to 2.2 in. (56mm) onto strand sizes 1/4 in. to 1/2 in. (6-12mm) diameter
- Simple capstan drive yields a reliable smooth and quiet machine.
- Dual wire magazines for loading two coils of stainless steel lashing wire
- Lightweight and compact: Unloaded weight 40 lbs. (34kgs.); only 10.6 in. O.D. x 22.5 in. long (26 x 57cm).
- Furnished with a sturdy wooden carry case, a bridle pull rope with snap hooks, a screwdriver, a wrench, and an instruction manual.

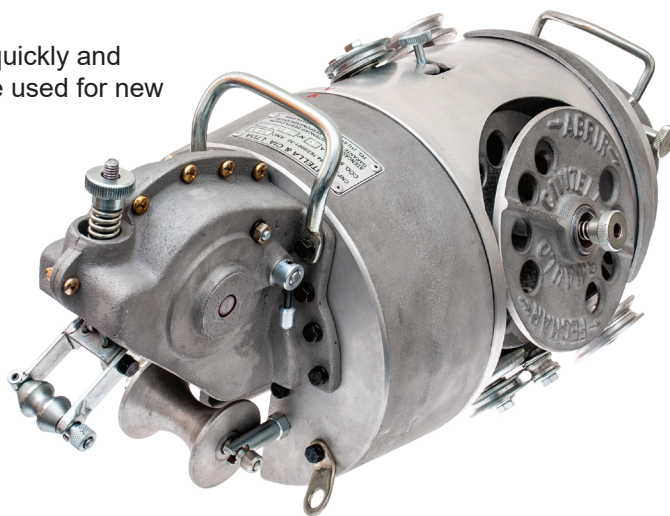

### Ordering Information

P/N	Description	Package Weight
71000	Civitella Cable Lasher	40 lbs. (18.1kgs)

# Super G Cable Lasher

The largest of the GMP Lashers, this unit is designed to lash large single or combination of aerial cable up to 5" diameter to a supporting strand. Can be used for new installs or with existing cables in place.



- Lashes cable from about 2-1/2" to 5-1/4" outside diameter or multiple cables up to 5-3/4" combined outside diameter
- Lashes on strand from 11/32" to 1/2" diameter with one or two spiral wrappings of .061" or .065" diameter stainless steel wire
- Nominal spacing between wraps is approximately 18-19" (46 to 48cm)
- Parallel-pull capability overcomes most terrain obstacles
- Wire tension constant regardless of amount on spool
- No lasher backroll when pulling force removed
- Front rollers guide cables through the machine
- All smooth edges throughout help protect against cable damage
- Ergonomic design makes it easy to handle
- Each lasher includes a 6 ft. bridle rope assembly with snap hooks, an information and operations manual and a heavy duty storage chest
- Lasher weighs 58 lbs. without wire

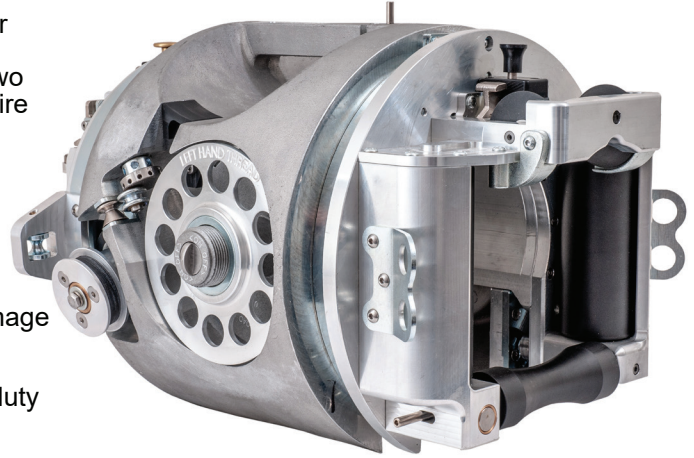

### Ordering Information

P/N	Description	Package Weight
10505	Super G Cable Lasher	58 lbs. (26.3kg)

### HD Cable Roller Dolly for Super G Cable Lasher

The HD Cable Roller Dolly is placed on the strand ahead of the Super G Cable Lasher. The Super G lasher pushes the dolly while it captures the 3 cables and places them into the ideal configuration for a perfect triangle wrap forming a compact and stronger lash. *Note: The Universal HD Cable Block Pusher (70018) is required when using this tool.*

P/N	Description	Weight
70697	HD Cable Roller Dolly	21 Lbs. (9.5kg)



### Lashing Wire

Stainless Steel Lashing Wire is used in a lasher to lash an aerial cable or combination of cables to a supporting strand.

- A specially controlled annealing process yields a uniform, fine grain structure throughout wire length and cross section for best results
- The GMP lashing wire is packaged as 6 coils per carton
- Is available in a 430, 302, and 316 stainless steel alloy

### SPECIFICATIONS:

P/N	Qty.	Alloy	Dia.	Ft. Coil	Meter Coil	Wt. Coil
71530	6	430	045	1200	365.8	6.5 lbs.
71532	6	430	065	450	137.2	5.3 lbs.
71533	6	302	045	1200	365.8	6.3 lbs.
71534	6	316	045	1200	365.8	6.4 lbs.
71535	6	302	038	1600	487.7	6.3 lbs.
71541	6	316	065	450	137.2	5.3 lbs.



### D Lashing Wire Clamp

- All steel clamp securely attaches two lashing wires or a #6 ground wire on 1/4 to 7/16" (6-11mm) strand
- Two grooved plates fit on opposite sides of the strand
- Mechanical galvanized finish provides extra corrosion resistance
- Packaged 100 pcs. per box

**P/N 07886** Weight: 15 lbs. (6.8kgs)



### E Lashing Wire Clamp

- Similar to the D Lashing Wire Clamp, this one-piece stamping is formed to fit on opposite sides of the strand.
- Offered in two sizes for standard strand and large strand
- Packaged 100 pcs. per box

**P/N 81460** for 7/16" (11mm) 100/box  
Weight: 11 lbs. (5.0kgs)

**P/N 81461** for 9/16" (14mm) 100/box  
Weight: 11 lbs. (5.0kgs)

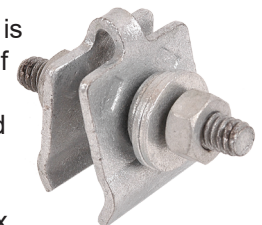

### Lashing Wire Grip

- Used to temporarily secure lashing wire under tension prior to placing a permanent D or E Lashing Wire Clamp

**P/N 08605** Weight: 10 oz. (0.3kgs)



### Overlash Aerial Cable Guide

- Used for both new construction and overlash to an existing bundle ahead of a lasher during the lashing operation
- The unit has a 2 3/4" (70mm) cable capacity

**P/N 08007** Weight: 11 lbs. (5kg)

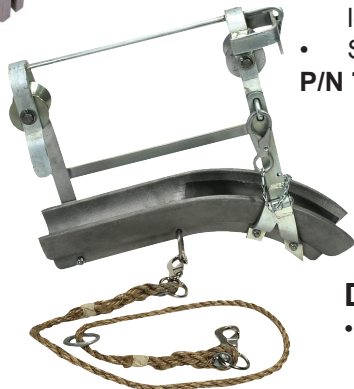

### Universal Heavy-Duty Cable Block Pusher

This simple tool makes the lashing process smoother by maintaining the proper cable lead between the lasher and the cable block.

- The slotted tube has rotatable sleeves at each end to lock the unit on the strand
- Standard length 24 in. (61cm)

**P/N 70018** Weight: 3.0 lbs. (1.4kgs)



### F Cable Block

- This block is similar to the D Cable Block, but is also used for overlashing cables up to 2 3/4" (70mm) in diameter
- Optional spring loaded keeper available to keep lighter cables on the roller for the highest level of cable security
- Steel inserts on the underside of each strand hook provide smoother sliding during lashing and less wear
- Bi-Directional cam keeps block "locked" on strand during pull-out, but will slide with lasher during lashing operation
- P/N 08093** Weight: 3.8 lbs. (1.7kg)



### D Cable Block

- Used on 1/4 to 3/8" (6-10mm) strand and can support a single cable up to 2 3/4" (70mm) in diameter
- Steel inserts on the underside of each strand hook provide smoother sliding during lashing and less wear
- Bi-Directional cam keeps block "locked" on strand during pull-out, but will slide with lasher during lashing operation

**P/N 72680** Weight: 3.8 lbs. (1.7kg)



### Aluminum 750 Cable Block

A block used on 1/4" new strand when lashing cable up to 2 3/4".

- Bi-directional cam keeps block stationary during cable pull-out
- Eye hook on cam handle allows placement using Wire Raising Tool

**P/N 75000** Weight 4 lbs. (1.81kgs)



### Pole Mount Block

This 2 3/4" (70mm) single roller block is designed to support fiber optic, self-support or small copper cables at poles.

- Mounts on the 5/8" (15.88mm) bolt of a 3 bolt clamp. Has a zinc-plated steel frame and retainer to keep the cable or 1/4" (6mm) dia. poly rope in the block.
- Has a rating capacity of 50 lbs. max. (22.6kg)

**P/N 70335** Weight: 3.5 lbs. (1.6kg)



### Multi Sheave Cable Block

Heavy duty Multiple Sheave Cable Blocks are used to simultaneously support two or three cables prior to lashing to a supporting suspension strand.

- Bi-directional cam keeps block stationary during cable pull-out
- Eye hook on cam handle allows placement using Wire Raising Tool

**P/N 10553** Weight 15 lbs. (7kgs)

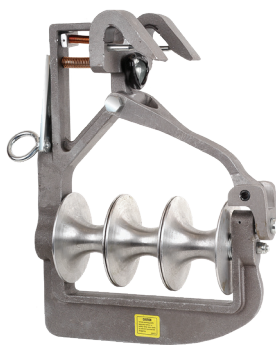

### G Cable Block

This block is functionally similar to our D Cable Block. This larger tool can be used with the G Cable Lasher to handle cable up to 5 in. (127mm) dia. and features strand hooks to accommodate 3/8 – 3/4 in. (10-19mm) diameter strand.

- This heavy duty block is made from 100% heat treated aluminum alloy
- Contains two vertical side rollers in addition to the cable sheave to minimize cable friction during pulling in

**P/N 01051** Weight: 6 lbs. (3kg)



## 2" Econo Block

This economical block is used for new strand and overlash work.

- Can accommodate up to a 2" (5cm) cable
- The strand wedges in the "V" notch of the sturdy cast aluminum frame
- The spring-loaded strand retaining pin will clear two previously lashed 3/4" (19.05mm) cables for overlashing
- A rotating gate keeps line or cable on the roller

**P/N 10701 Rubber Roller**

Weight 2 lbs. (.907kgs)

**P/N 10700 Aluminum Roller**

Weight 2 lbs. (.907kgs)



## Clip On Block

This steel block is used to support cable up to 1" (2.54cm) during cable pull-out.

- The block fits over existing cable bundles up to 2" (51mm)
- The pliable urethane roller is forgiving of field abuse.
- sold in package of 10

**P/N 87265** Weight 11 lbs. (.5kgs)



## Overlash Roller

Simple and effective, this block handles cable or bundles up to 4" and 2.75" respectively.

- The roller is made from industrial conveyor bearing material for high abrasion resistance with low rolling friction.
- A spring-latch gate encloses cable and strand within the frame **P/N 87210** 4" Weight 1 lb. (.45kg)
- **P/N 87213** 2.75" Weight 1 lb. (.45kg)



## B Overlash Cable Block

This block lets you overlash to cable bundles up to 2" (50mm) across

- Ideally suited for messenger strands from 1/4 to 3/8" (6-10mm)
- A keeper retains the block on the messenger, and the fiber cable is positively retained in the block.
- The block's gritty non-skid surface rests against the strand and minimizes sliding during the pulling in of cable.
- The frame is equipped with an anti-friction roller and a lever actuated keeper bar which encloses the cable in the block



**P/N 70336** Weight 1 lbs. (.45kgs)

## Wire Raising Tool

A good all around tool that gives you the flexibility to place steel strand and aerial telephone wires at the same time. Use with GMP Extension Handles (Lay-up Sticks)

**P/N 06355** 1 lb. 3 oz. (.54kg)



## FIBERGLASS EXTENSION HANDLES

The fiberglass extension handles are made of light tubular fiberglass, 1 1/4 in. in diameter.

- Are completely interchangeable with and slightly lighter than the wooden handles
- The life of the fiberglass handle is greater than that of the wooden handle. Each has a special surface treatment for user protection from fiber pickup.
- Each handle has a highly visible yellow color for extra safety in bad weather
- The handles are available in the standard 6 ft. length as well as a 3 ft. length

**P/N 24193** 3 ft. Fiberglass Handles 1 lb. (.45kg)

**P/N 24194** 6 ft. Fiberglass Handles 2 lbs. (.90kg)

**P/N 15310** 21 ft. (6.4 m) Fiberglass Handles Set Includes: three - 6 ft. handles, one -3 ft. handle



## ECONO CABLE BLOCKS

Supports fiber optic cables during cable pullout. Designed to prevent cables from catching or snagging.

- The frames are made from welded steel
- The easy clip-on design makes for fast work when time is money
- The unique housing profile keeps the lashing machine (P/N's 71422 and 86070) from riding over the unit
- The glass-filled nylon rollers are forgiving of field abuse
- The compliant 3" rubber roller reduces the chance of damage to your cable during pullout
- All steel parts are zinc plated for corrosion resistance

**P/N 74050** 1" Econo Cable Block Weight: 1 lb (.45kg)

**P/N 74052** 1" Econo Cable Block with Dual Rollers Weight: 1.4 lb (.63kg)

**P/N 74051** 3" Econo Cable Block with Rubber Roller Weight: 1.8 lb (.82kg)



## Heavy Duty 45 & 90 Deg. Fiber Optic Corner Blocks

These heavy duty corner blocks are used to guide ADSS and fiber cable and evenly distribute the load on the cable when pulling around corners.

- Welded and painted steel frames
- Working Load Limit 750 lbs.
- Comes with high strength aluminum rollers with self lubricating bearings
- Accepts fiber optic cables up to .688 in. or innerduct on a 23 in. bending radius
- Aluminum cable retaining roller helps prevent the cable from jumping off of the rollers
- Mounts on our Pole Bracket (P/N 70550)

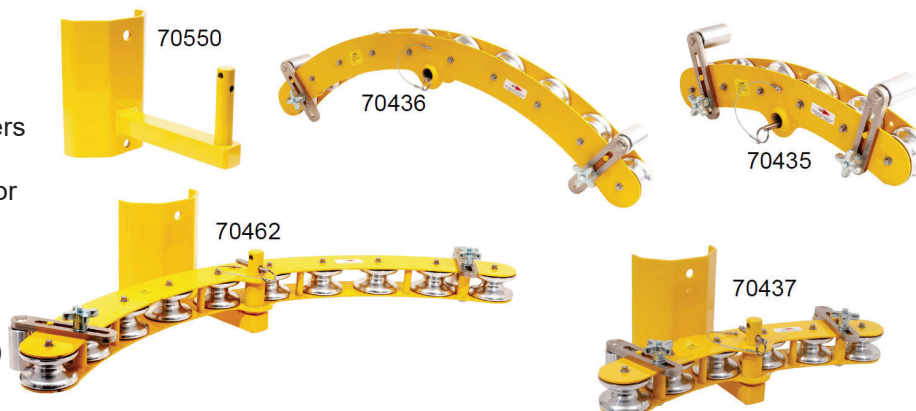

PART #	DESCRIPTION
70550	MOUNTING BRACKET, FOR FIBER CORNER BLOCKS Weight 11.5 lbs. (5.21kg)
70436	90° Corner Block W/Heavy Duty Aluminum Rollers Weight 20.8 lbs. (9.43kg)
70435	45° Corner Block W/Heavy Duty Aluminum Roller Weight 13.4 lbs. (6.08kg)
70462	Mounting Bracket W/90° Corner Block Weight 32.3 lbs. (14.65kg)
70437	Mounting Bracket W/45° Corner Block Weight 24.9 lbs. (11.30kg)

## Corner Blocks 45 And 90 Degree

These rugged and lightweight corner blocks are used to guide cable and evenly distribute the load on the cable when pulling around corners.

- Welded and painted steel frames.
- Order with either high strength plastic rollers or aluminum rollers.
- New and improved plastic roller now allows you to pull with Poly rope.
- Accepts up to a 1 3/8" diameter cable or innerduct on a 23" bending radius.
- Cable retaining roller helps prevent the cable from jumping off of the rollers
- Mounts on our Ratcheting Pole Bracket **P/N 70372**

**P/N 70439** 45° Corner block w/ Plastic rollers - Weight 8 lbs. 14 oz. (4kg)

**P/N 70450** 45° Corner block w/ Aluminum rollers - Weight 10 lbs. 1 oz. (4.6kg)

**P/N 70438** 90° Corner block w/ Plastic rollers - Weight 13 lbs. 12 oz. (6.2kg)

**P/N 70449** 90° Corner block w/ Aluminum rollers - Weight 15 lbs. 14 oz. (7.2kg)



*Shown with P/N 70372 Pole Mount Bracket*



**P/N 70440**  
Vertical Angle Adapter



## Universal Stringing Blocks

Order P/N  
74135



Order P/N 74137  
Ball Clevis



Order P/N 74138  
Y-Clevis Ball



Order P/N 74139  
Ball Hook



Order P/N 74140  
Oval Eye Ball



Order P/N 74136  
Safety Ball Hook

These rugged universal blocks feature high strength and low weight at a value price. With a working load limit of 2,500 lbs., they can be configured with 5 different mounting options. Permanently lubricated bearings provide long term durability and an extreme temperature operating range.

*Pick your mount and block from the pictures above and use the associated part numbers to order.*

- 8.1 – 13.0-lbs depending on configuration
- 7" Block (O.D.)
- 3" Sheave (rim width)
- 3-1/8" Width (throat)
- Cast from A356 Aluminum and heat treated
- Working Load Limit of 2,500 lbs.
- Double shielded, deep groove ball bearings
- Permanently lubricated to withstand -5F to 250F
- Profile machined groove for concentricity
- A complete line of cross arm brackets available

## Accessory Cross Arm Brackets



Order P/N 74147  
Adapter Fits - 5 3/8" x 6 1/4"  
Cross Arm

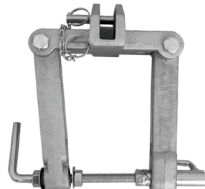

Order P/N 74148  
One Handed Installation -  
4 1/2" x 5 1/2" Cross Arm

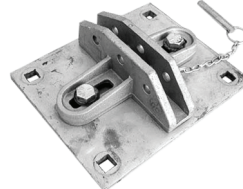

Order P/N 74149  
Adapter Fits - 6 1/2" x 8"  
Cross Arm

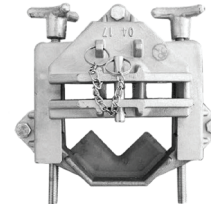

Order P/N 74150  
Adapter with Handles for  
Tie Top Post Insulator

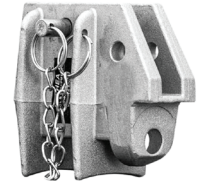

Order P/N 74151  
Adapter for Clamp  
Type Insulator

## Typical ADSS Installation

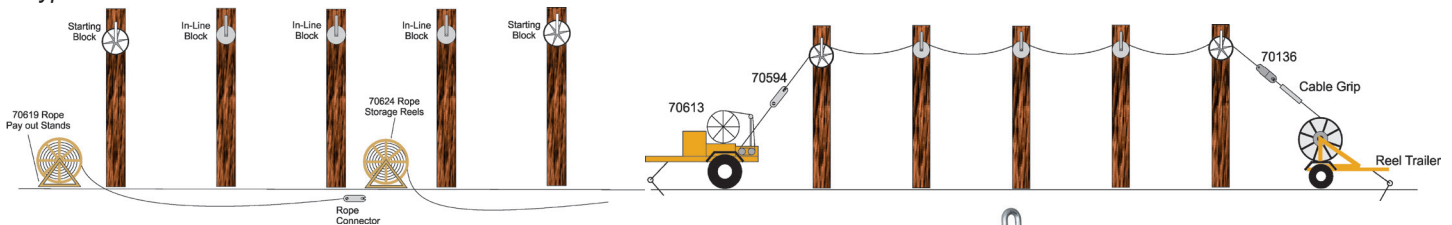

### Starting Block

The block has a safety gate and steel side frames. The sheave rides on ball bearings.

O.D.: 11.8"  
Groove Width: 1.77"  
Root Dia.: 9.64"  
Wt.: 15.4 lbs.  
W.L.L.: 2646 lbs.  
P/N 70595  
P/N 70596 w/lug



### Large Starting Block

The large diameter profiled groove helps protect the cable. The swivel oval eye, cable gate and cable retaining pin make it easy to use. The sheave rides on ball bearings.

O.D.: 18.50"  
Groove Width: 2.17"  
Root Dia.: 15.16"  
Wt.: 30.8 lbs.  
W.L.L.: 5291 lbs.  
P/N 70621

*ADSS is an acronym of All-dielectric Self-supporting Optical Cable. ADSS cable is designed for aerial self supporting application at short, medium and long span distances.*

## Ratcheting Telco Cable Cutter

These rugged cutters are designed especially for cutting communications cable up to 3 3/8" (85mm) in dia. Because of their 19" (483mm) size, they are extremely popular for cutting cable in tight spots like manholes, ditches or riser closets.

- They are ideal for cutting soft (annealed) copper conductor cable with maximum capacity including 1800 pair 24 AWG or 2700 pair 26 AWG communications cables
- The ratchet mechanism features reversible two-speed cutting (fast action/low leverage or normal action/high leverage) for extra power
- Furnished with a full grain leather scabbard to protect the cutter head

P/N 75250 Weight: 3.5 lbs. (1.6kg)



## 336 ACSR Ratchet Cutter

- Reduced hand force for easier cutting
- Patented two-step ratchet mechanism requires fewer strokes per cut
- Cuts up to 336 MCM ACSR, 400 MCM Copper, and 600 MC M Aluminum
- Quick release lever opens blades easily in every cutting position, to allow removal of the cable before completion of cut
- Hardened steel cutting blades for lasting strength and sharpness
- Locking lever keeps handles closed for easy transport; fits in a tool box or bag
- Selectively-hardened blades and reduced hand force make it easier to cut ACSR
- 10 1/4" (260mm) long

P/N 01817 Weight: 1.5 lbs. (.7kg)



## Texas Cutter For Telco

With its long 36" handles and big 3 3/8" blade opening, these rugged cutters definitely command respect.

- They're built to make clean cuts through even the thickest 1800 pair 24 AWG or 2700 pair 26 AWG lead or polyethylene-jacketed cable
- Its maximum cutting capacity is 3 3/8" (85mm) diameter

P/N 66250 Weight: 9 lbs. (4kg)



## Splicer's Scissors

These heavy-duty scissors are so comfortable and easy to use, they're practically an extension of you own hand.

- Each is hot-forged from high-carbon 1060 steel, with a bright nickel finish for long-lasting good looks
- There's a scraper/filer surface to help speed wire prep, and two notches (one for 19 AWG wire, the other for 22-24 AWB wire for fast, smooth strips.
- Each cutting edge is 1 7/8" (4.8cm) Length: 1 1/8" (2.9cm) of the upper blade is serrated to keep the cable from slipping while you cut. The points are rounded for extra safety

P/N 01008 Splicer's Scissors 3 oz. (85g)

P/N 70019 Splicer's Scissors Pouch Only 3 oz. (85g)

P/N 24471 Splicer's Skinning Knife 3 oz. (85g)



## 3" Ratcheting Tel-Cutter

A compact, one-handed, light weight ratcheting tool for cutting copper communications cable up to 3" (76mm) in diameter.

- The cutter has a release lever to disengage the ratchet allowing the blades to open even in mid-cut
- Safety latch for locking blades in closed position for storing when out of service
- Features a rubber boot to lodge the stationary handle against your work surface and multiply your manual effort

P/N 01819 Weight: 2.5 lbs. (1kg)



70019  
Scissors not  
included



24471

## Manhole cover lifters aid in the removal and replacement of manhole covers and reduces strain put on the user.



### Manhole Cover Hook

A simple tool that's been used for years to pry loose conventional manhole covers.

- Made from hexagonal tool steel that's been specially hardened to prevent bending
- 26" (66cm) long

**P/N 08172** Weight: 4 lbs. (2kg)  
 NOTE: For actual removal of a cover please use one of our Manhole Cover Lifters.

### Manhole Cover Lifter

This ingenious tool simplifies the removal and replacement of typical telephone manhole covers while decreasing the strain on the user.

- The long handle provides useful leverage when removing and replacing manhole covers
- Each tool is made of an all-steel handle, sleeve, shank, foot and heat-treated alloy steel hook. Zinc plating is then applied to fight rust and rubber grips are placed on both handle and foot to prevent slippage.
- The open end of the hook can be locked inside the handle as an added safety feature when not being used.

**P/N 01368** Manhole Cover Lifter 9 lbs. (4kg)  
**P/N 13681** Manhole Cover Lifter w/Spiked Foot 9.5 lbs. (4.3kg)



Spiked Foot Option



Spiked Foot Option

### "E-Z Lift" Cover Lifter

The "E-Z Lift" cover lifter is the tool of choice by major telcoms for removing and replacing manhole and pullbox lids.

- Manufactured from solid 6061-T6 lightweight aluminum
- The built in mechanical advantage allows you to remove even the most stubborn cover, while letting the lifter do the work, not your back
- Has a link device that attaches to an "S" Hook which allows you to position the tool so the handle is vertical when lifting
- Has a urethane covered T-bar for extra traction on asphalt
- Optional spiked foot is available for improved traction on grass, sand, ice, snow or other loose surface

**P/N 70159** "E-Z Lift" Manhole Cover Lifter 9 lbs. (4kg)  
**P/N 70158** "E-Z Lift" Manhole Cover Lifter w/Spiked Foot 9.5 lbs. (4.3kg)

### Handhole Cover Hook

No bending over with this extended reach 35.5" long tool.

- The large triangle handle will allow the largest gloved hands a solid grip.
- The tool is made from 5/16" diameter electroplated steel.

**P/N 74123** 2 lbs. (.9kg)

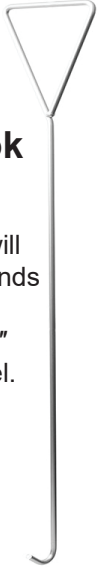

### Manhole Guard Rail

This high-quality guard helps protect field crews when working in and around manhole vaults. Each guard folds into a compact 2 1/2" (64mm) x 33 1/4" (844mm) rectangle, yet opens easily into a large 32" (813mm) wide by 32" (813mm) deep x 42" (1070mm) high cube

**P/N 06867** 40 lbs. (18kg)



### Handhole Cover Lifter

This tool simplifies the removal and replacement of typical handhole covers while decreasing the strain on the user.

- Manufactured from solid 6061-T6 aluminum
- The built-in mechanical advantage allows the user to remove even the most stubborn hand hole cover, letting the lifter do the work and not the user's back
- The adjustable lifting position allows for the optimal lifting angle for the hand hole cover
- The chain is 5 feet long to allow for easy positioning
- The urethane covered T-bar provides extra traction

**P/N 70408** 10.5 lbs. (4.8kg)





## Utility Manhole Cover Lifter

This lifter is for the individual faced with a wide variety of covers in their work environment.

- The plated steel tubular body has been made thicker for the typically heavier electric utility manhole covers
- The built in mechanical advantage allows you to remove even the most stubborn cover, while letting the lifter do the work, not your back
- A spiked foot is incorporated into the design for improved traction on grass, sand, ice, snow or other loose surface
- GMP offers multiple hooks or "keys" to be placed on the shackle at the end of the lifter's galvanized chain. This allows one tool to remove multiple cover types
- The keys are heat treated steel for extra strength and durability



P/N	Weight	Lifter 70066	Small J-Hook	Medium L-Hook	Large J-Hook
70151	9 lbs. (4kg)	X		X	X
70152	8.5 lbs. (3.8kg)	X	X		
70153	8.5 lbs. (3.8kg)	X		X	
70154	8.5 lbs. (3.8kg)	X			X
70155	9 lbs. (4kg)	X	X	X	
70156	9 lbs. (4kg)	X	X		X
70157	9.5 lbs. (4.3kg)	X	X	X	X



Small J-Hook



Medium L-Hook



Large J-Hook

## Manhole Cover Bolts And Wrenches

Pentagonal head bolts are machined from a tough grade of stainless steel designed for durability when fastening a manhole cover in place.

**GMP offers the bolts in two sizes:**

- 3 1/4" overall length threaded 5/8" - 11 with countersink chamfer under head **P/N 84530**
- 1 7/16" overall length threaded 1/2" - 13 with flat shoulder under head **P/N 84531**

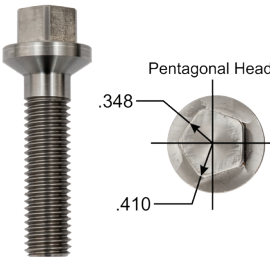
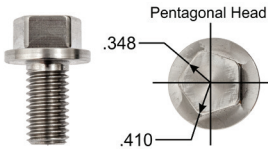

### Manhole Cover Wrench

Specifically designed for use on manhole cover bolts, this wrench has a pentagonal socket at one end which fits over the head of our manhole cover bolts, and a 3/4" (19mm) hole at the other for use with a rod or hook-end spinning wrench. It's made of heat-treated steel with a zinc-plated finish. **P/N 84540**

### Manhole Cover Socket Wrench

For those who want to use a powered driver we offer this pentagonal socket wrench that fits any impact tool with a 7/16" hex drive. **P/N 01375**

## Penta Buster®

The PENTA BUSTER tool is a patented, multi-purpose solution to the nagging industry problem of cleaning debris from the area surrounding the fasteners used in external ground-level service boxes. It grinds away the debris around service box enclosures with a ratchet that produces "teeth" that disappear at the flip of the wrist. Made with corrosion resistant 303 stainless steel.

The removable T-handle allows the base to be used with a standard 1/2" drive ratchet.

**P/N 33940** 3/4" Pentagonal PENTA BUSTER 804-5 (use with GMP bolts)

**P/N 33941** 9/16" Hex PENTA BUSTER 804-7

**P/N 33938** 3/8 to 1/2" ratchet adapter

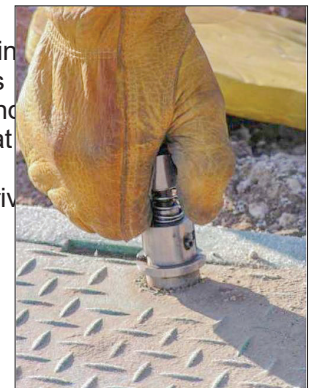

33940

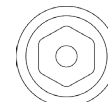

33941

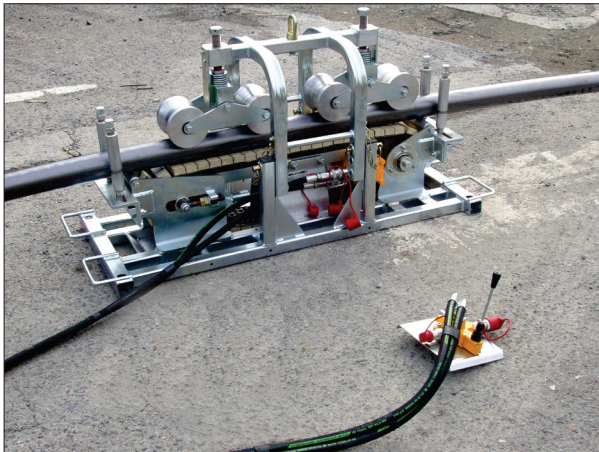

### Cable Pusher

The GMP Cable Pusher has been designed to assist the laying of electrical cables.

The unit has a profiled drive system to grip the cable, with a load applicator of adjustable upper rollers. The unit is hydraulically driven and is powered by a Portable Hydraulic Power Pack. Control Valve Module and Power Pack offered separately.

- The Cable Pusher is typically used in open trench work to assist a winch when laying large electrical cables
- The Pusher helps reduce the pulling tension on the cable end by "pushing" at a midpoint
- Works with cable sizes ranging from 1.25 - 6" (32 - 152mm) in diameter
- The Pusher is hydraulically driven, and powered by an optional Portable Hydraulic Power Pack
- A profiled belt is used to grip the cable, with a load applicator of adjustable upper rollers
- Maximum pushing force is 1540 lbs. (700kg) and a maximum speed of 33 ft. (10m) per minute
- Single lever, bi-directional control with variable speed control
- The pushing force is adjustable through a relief valve
- A wide selection of accessory rollers are available to help guide the cable

**SPECIFICATION:**

Cable Size:	1.25 -6" (32-152mm) O.D.
Dimensions:	55" W x 20" L x 31" H (500mm x 1390mm x 770mm)
Max Push:	1543 lbs. (700kg)
Max Speed:	33'/min (10m/min)
Controls:	Single Lever for Push/Pull Operations
Drive System:	Hydraulic
Min Requirement:	4.75 gpm/870 psi (18 Ltr/min at 60 bar)
Weight:	441 lbs. (200kg)

Cable Pusher for 1.25 - 6" (30-150mm) Power Cable  
**P/N 89760** Weight: 441 lbs. (200 kgs)

### Fiber Optic Sheave And Shackle

This new sheave and shackle, or "bicycle wheel", combination is designed to accommodate the special handling needs of pulling fiber optic cable. Among the unique features are a lightweight design, one-size shackle and the reduction of loose parts.

- 32" (81cm) and 40" (102cm) sizes are split to accommodate less than 32" diameter manhole
- Sheaves are lightweight aluminum construction with self-lube bearings
- Pins on shackles prevent cable damage when not under tension

P/N	Description	Weight
71548	Underground Fiber Optic Shackle (requires Fiber Optic Sheave)	20 lbs. (9kg)
71549	Overhead Fiber Optic Shackle with 24" (61cm) Fiber Optic Sheave	29 lbs. (13kg)
71550	24" (61cm) Fiber Optic Sheave only	13 lbs. (6kg)
71551	Underground 32" (81cm) Split Fiber Optic Sheave only	18 lbs. (8kg)
71552	Underground 40" (102cm) Split Fiber Optic Sheave only	30 lbs. (17kg)
71554	Overhead Fiber Optic Shackle (Requires 24" Fiber Optic Sheave)	16 lbs. (7kg)
71560	Underground 24" (61cm) Fiber Optic Sheave & Shackle Assembly - WL: 2,000 lbs.	33 lbs. (15kg)
71561	Underground 32" (81cm) Split Fiber Optic Sheave & Shackle Assembly - WL: 1,250 lbs.	38 lbs. (17kg)
71562	Underground 40" (102cm) Split Fiber Optic Sheave & Shackle Assembly - WL: 1,250 lbs.	50 lbs. (23kg)





### Jamb Skid

Used to support quadrant blocks and sheaves when pulling cable through underground conduit.

- Lightweight, constructed primarily of aluminum
- Corrosion resistant
- Top swivels for easier placement within vault.
- Includes (2) (P/N 71717) 1 5/16" (33mm) diameter locking pins to lock the jamb skid height and secure the sheave or quadrant block
- Accepts all GMP sheaves and quadrant blocks with widths up to 7" (178mm)
- Includes a base unit to accept the upper extensions
- Do not exceed 10,000 lbs. cable tension when using the short or intermediate extension.
- Do not exceed 5,000 lbs. cable tension when using the long extension.

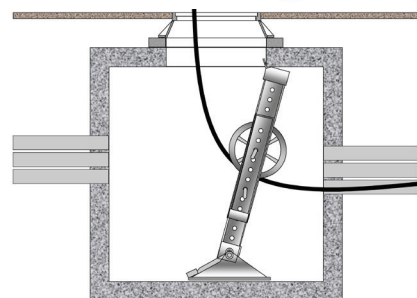

**P/N 70640** 48" to 85" (121.9 to 215.9cm). Includes 43" (109.2cm) extension. Rated at 10,000 lbs. cable tension.

**P/N 70643** 84" to 121" (213.4 to 307.3cm). Includes 76" (200.7cm) extension. Rated at 10,000 lbs. cable tension.

**P/N 70646** 114" to 151" (289.6 to 383.5cm). Includes 109" (276.9cm) extension. Rated at 5,000 lbs. cable tension.

## High Density Fiber Placing Solutions

### Jam Skid With Split Sheave Kit

This new split sheave (bicycle wheel) and jamb skid combination is designed to accommodate the special handling needs of pulling fiber optic cable.

- 32 in. (81cm) and 40 in. (102cm) sizes are split to accommodate less than 32 in. Diameter manhole
- Sheaves are lightweight aluminum construction with self-lube bearings

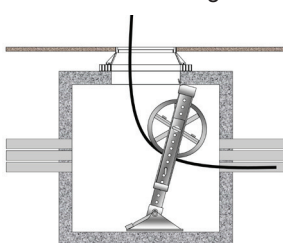
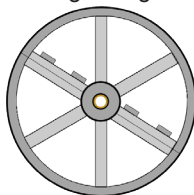

*Jam Skid With Split Sheave Kit*

PART #	JAM SKID W/SPLIT SHEAVE KIT
71558	32" Split Sheave With 43" Jamb Skid
71556	40" Split Sheave With 43" Jamb Skid
71559	32" Split Sheave With 76" Jamb Skid
71555	40" Split Sheave With 76" Jamb Skid
71553	32" Split Sheave With 109" Jamb Skid
71557	40" Split Sheave With 109" Jamb Skid



### Fiber Optic Ez-Exit

The fiber optic cable EZ-Exit tool eliminates damage to your fiber by easily guiding fiber optic cable past the sharp edges of a manhole chimney. The easy clamping feature allows the tool to be quickly installed in less than 30 seconds, reducing the total setup time of a fiber pull and ultimately saving MONEY!!! The tool provides a rigid, low friction shoe that guides fiber over the sharp edges at the top and bottom of a manhole chimney while maintaining a bend diameter of 45" to accommodate up to some of the largest fiber cables.

**P/N 90060 Fiber Optic Easy Exit**  
Weight: 39.20 lb (17.8kg)

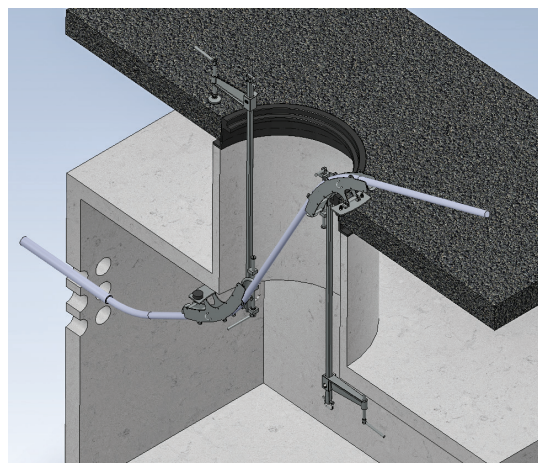

### Specifications

- Length: 15 inches
- Width: 14 inches
- Height: 68 inches
- Max Clamping Length: 51 inches without extensions
- Weight: 39.20 lbs.
- Working Load Limit: 600 lbs.



**Reel Buck**

A tough, easily maneuvered and portable frame that's ideal for supporting any reel up to 84" (2134mm) diameter.

- Two welded, rectangular steel members make up the frame.
- Designed for one-person.
- Will accommodate the Corning FlexNap™ cable reels.
- The frame is protected with a durable powder coat finish to prevent corrosion.
- Spindle bar included.

P/N	Max Width (mm)	Max Drum (mm)	Load Capacity (kg)	Weight (kg)
71669	36" (914)	50" (1270)	1200 lbs. (544)	80 lbs. (36)
71678	54" (1372)	50" (1270)	1200 lbs. (544)	90 lbs. (41)
71679	54" (1372)	84" (2134)	500 lbs. (227)	100 lbs. (45)



**Reel Caddy**

These large diameter Reel caddies can be used to support and dispense drop cable quickly and easily. The caddies are lightweight and fold flat for compact storage. They're fabricated from durable painted steel tubing for years of dependable service.

The reel caddy supports reels up to 30" (762mm) diameter and 33" (838mm) with XL version. They easily accommodate multi port deployment on cardboard or plastic reels. The caddies are quick and simple to setup with one hand.

Will support reels up to 200 lbs. (91kg) with a minimum 1 1/2" (38mm) spindle diameter.

Reel Caddy (w/o flange) **P/N 70404** Weight: 10 lbs. (4.54kg)  
 Reel Caddy (with flange) **P/N 70403** Weight: 10 lbs. (4.54kg)  
 Reel Caddy XL **P/N 70407** Weight: 15.3 lbs. (6.94kg)

**Pole Mount Spindle**

Equipped with a Ratchet Binder using a 2" (51mm) wide web to provide a sturdy, yet temporary, attachment to a pole for cable reels.

Pole Mount Spindle Small 1.5" (51mm) Spindle Diameter, Max Reel Width 9" (229mm) **P/N 75984** Weight: 11.3 lbs. (5.12kg)

Pole Mount Spindle Large 2.5" (63mm) Spindle Diameter, Max Reel Width 24.5" (622mm) **P/N 75985** Weight: 24.2 lbs. (10.98kg)

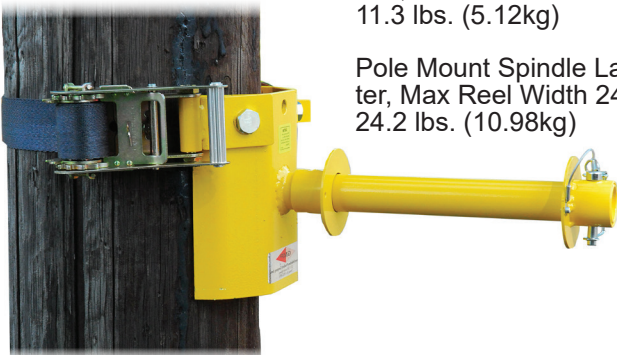

Reel not included

## CR Collapsible Power Reel For 2 7/16" Bayonet

The CR Collapsible Power Reel is used for rapidly stringing or taking up wire or small diameter cable. Ideal for placing or removing aerial cable, taking down wire, or pulling winch line into conduits.

- Can be used for pulling in poly rope or tape, where the reel will only be used as a pulling capstan and not as a storage device
- Has a capacity of 1600 ft of 1/4" (490m of 6mm) wire rope with a maximum allowable pull of 3500 lbs. Bare Drum (1600kg). Can also store a 200 pound coil of wire.
- Reel O.D. 28" (expanded), 18 3/4" (collapsed). I.D. 20"

**P/N 08136** Weight: 70 lbs. (31.75kg)

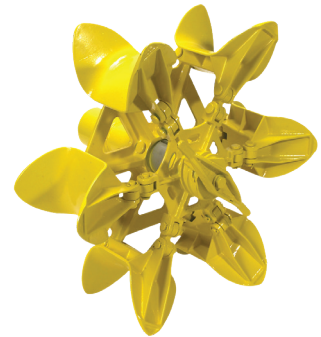

## C Drop Wire Reel

This light-weight tubular reel provides an easy way to store and unreel drop wire, coaxial or other small diameter cables.

- Adjusts to two different widths: 4.25" or 5.00" (108mm or 127mm)
- Will hold any coil of wire with a minimum 15" diameter eye and a nominal O.D. of 25"
- Features an adjustable brake to control the payout speed
- It can hold 1000 ft of PE-7 .160" x .295" standard drop wire, 1250 ft of .140" x .275" drop wire or, 500 ft of .130" x .220" drop wire.

**P/N 75980** Weight: 38 lbs. (17kg)



## RS Power Reel

The RS Power Reel is intended for use in pulling aerial cable with a small size wire rope used as a pulling line. Also may be used for paying out the rope with the spool mounted either on the winch drum shaft or on the pole spindle.

- Perfect for utility pole work, this easy to use reel consists of a spool, driving and pole spindles, and two brake assemblies, one on each spindle
- Can be mounted on either a drive or pole spindle and has a 24 3/4" diameter O.D. and a 6" diameter hub
- Driving spindle mounts on any 2 7/16" (62mm) diameter winch extension shaft with a bayonet or pin type mount, while the pole spindle can support a spool on a pole
- The maximum allowable pull is rated for 2000 lbs. (907kg)
- Spool is made of heavy gauge steel with a reinforced exterior facing. Has a durable, bright yellow finish.



P/N	Description	Spool Width	Rope Diameter	Capacity	Weight
<b>83660</b>	RS Power Reel 6 in. (152mm) (Complete Assembly that includes 83662, 83663 and 83664)	6" (15cm)	1/4" (6mm)	2000 ft (610m)	126 lbs. (57kg)
<b>83662</b>	Spool only 6 in. (152mm)				50 lbs. (23kg)
<b>83663</b>	Drive spindle and brake only for 6 in. (152mm) spool				29 lbs. (13kg)
<b>83664</b>	Pole spindle and brake only for 6 in. (152mm) spool				47 lbs. (21kg)
<b>83669</b>	RS Power Reel 12 in. (304mm) (Complete Assembly that includes 83666, 83667 and 83668)	12" (30cm)	1/4" (6mm)	4000 ft (1220m)	160 lbs. (73kg)
<b>83666</b>	Spool only 12 in. (304mm)				72 lbs. (33kg)
<b>83667</b>	Drive spindle and brake only for 12 in. (304mm) spool				33 lbs. (15kg)
<b>83668</b>	Pole spindle and brake only for 12 in. (304mm) spool				55 lbs. (25kg)
<b>83665</b>	Reel brake assembly only				7 lbs. (3kg)

## Capstan

This general purpose capstan is used for a wide variety of pulling and hoisting applications.

- Cast from a high strength aluminum alloy for low weight
- Will fit on any 2 7/16" (62mm) diameter winch extension shaft equipped with a bayonet or pin type mount
- The working surface is 7 1/4" diameter x 8" (184mm x 200mm) wide. The maximum allowable pull is 4000 lbs. (1814kg).

**P/N 10727** Weight: 21 lbs. (9.5kg)



## Pole Trailer Light Bar

Thanks to GMP's Pole Trailer Light Kits you can transport utility poles with greater visibility while meeting DOT requirements and only adding minimal width to your trailer.

- The frame is made from an extruded aluminum weldment with a durable bright yellow polyester powder coating.
- D.O.T. approved lights (bulb or LED depending on model) and reflectors are mounted on the back and both sides.
- The unit comes with a 40 ft (12.2m) 18 gauge S.O. trailer cord with a heavy-duty 4-way or 6-way trailer lug for plugging into either the trailer or the vehicle pulling the trailer. This gives motorists the added information of turn signals and brake lights; not just blinking lights. Environmental concerns are also reduced as our kits don't use disposable batteries.
- Positive attachment to the pole is created with an over center chain binder that uses 5 ft (152cm) of chain and hardened steel spikes that bury in the pole when the binder is tightened on the wooden pole only version.
- Heavy duty strap binder version available for attaching to both wood or non-wooden poles.
- Sockets for both the 4-way and 6-way plugs can be ordered separately.



P/N	Description	Weight
70274	46" (117cm) wide w/4-way Plug for wood poles only	26 lbs. (12kg)
70276	46" (117cm) wide w/6-way Plug for wood poles only	26 lbs. (12kg)
70277	24" (61cm) wide w/4-way Plug for wood poles only	14 lbs. (6.5kg)
70278	24" (61cm) wide w/6-way Plug for wood poles only	14 lbs. (6.5kg)
71566	46" (117cm) wide w/7-way RV Plug for wood or non-wood poles	26 lbs. (12kg)
71567	46" (117cm) wide w/4-way Plug for wood or non-wood poles	26 lbs. (12kg)
71569	46" (117cm) wide w/6-way Plug for wood or non-wood poles	26 lbs. (12kg)



Chain Binder mount for wooden poles only.



Strap mount for wood and non-wooden poles

## Umbrellas

Whether working in a bucket, or on the ground, GMP umbrellas provide shelter from the sun. GMP offers a choice of rugged umbrellas, and a complete line of accessories for maximum mounting and angle adjustment flexibility. Choose between our Model D Umbrella (**P/N 80920**) for standard use, or our Dielectric Umbrella (**P/N 70352**) which is rated to 40kV per ASTM D-149 to help reduce the potential of electrical shock when working near power conductors.

- A tough plastic 68" (173cm) diameter umbrella cover is colored safety yellow on top (custom company logos available upon request)
- A reflective white underside cuts down on the interior heat absorption and is vinyl-coated; nylon rib-end pockets keep the frame from tearing the cover
- Self-sealing waterproofed, waxed stitching, and improved construction using a nylon sleeve and rib retainers for attaching the frame's six (6) collapsible fiberglass ribs
- The ribs connect at a ring-type lock that slides along the pole to open and close the umbrella. To lock the ring when open, just slide it over the set pin in the pole and rotate it.
- The 43" (109cm) long wooden upper pole has a male ferrule so you can attach the 29" (74cm) long wooden lower pole for a full height of 6' (1.83m)



 Use the Dielectric Umbrella when working near power conductors to help reduce potential sources of electrical shock



**P/N 71649** Tripod Kit shown with **P/N 70098** Model D Umbrella.



**P/N 71647**  
Angle Adapter & 1 pc.  
Pole External



**P/N 71572**  
Angle Adapter



**P/N 28210**  
Bucket Holder

*Note: Bucket holder must be used with **P/N 71647** Angle Adapter & 1 pc. Pole Extension.*

P/N	Description	Weight
<b>28210</b>	Holder Bucket for Umbrella Accommodates 1 PC Pole Ext <b>P/N 71647</b>	1.75 lbs. (.79kg)
<b>71572</b>	Adapter, Angle Umbrella	1.75 lbs. (.79kg)
<b>71647</b>	Adapter, Angle with 1 pc Pole Ext	2.5 lbs. (1.13kg)
<b>71649</b>	Kit Tripod w/Bag	37 lbs. (16.7kg)
<b>70098</b>	Umbrella D w/o Lower Pole Assembly	6.75 lbs. (3.06kg)
<b>80920</b>	Umbrella D with 72" Wooden Pole	9 lbs. (4.1kg)
<b>70352</b>	Umbrella Dielectric with 72" Fiberglass Pole—Rated to 40 kV per ASTM D-149	7.5 lbs. (3.4kg)
<b>80921</b>	Case, Umbrella	1 lb (.453kg)



GMPtools.com

show cat ver 2025.indd AKK 03/19/2025

GMP reserves the right, without notice, to make changes in equipment design or components as progress in engineering or manufacturing methods may warrant. All information contained herein is subject to such change.