

# GMP 'D' CABINET BALCONY #79283 ASSEMBLY INSTRUCTIONS



TOOLS BUILT TO GO THE DISTANCE

3111 Old Lincoln Highway

Trevose, PA 19053-4996

Tel: 215-357-5500

Fax: 215-357-6216

E-mail: [info@GMPtools.com](mailto:info@GMPtools.com)

# STEP 1

## GMP 'D' CABINET BALCONY AS RECEIVED

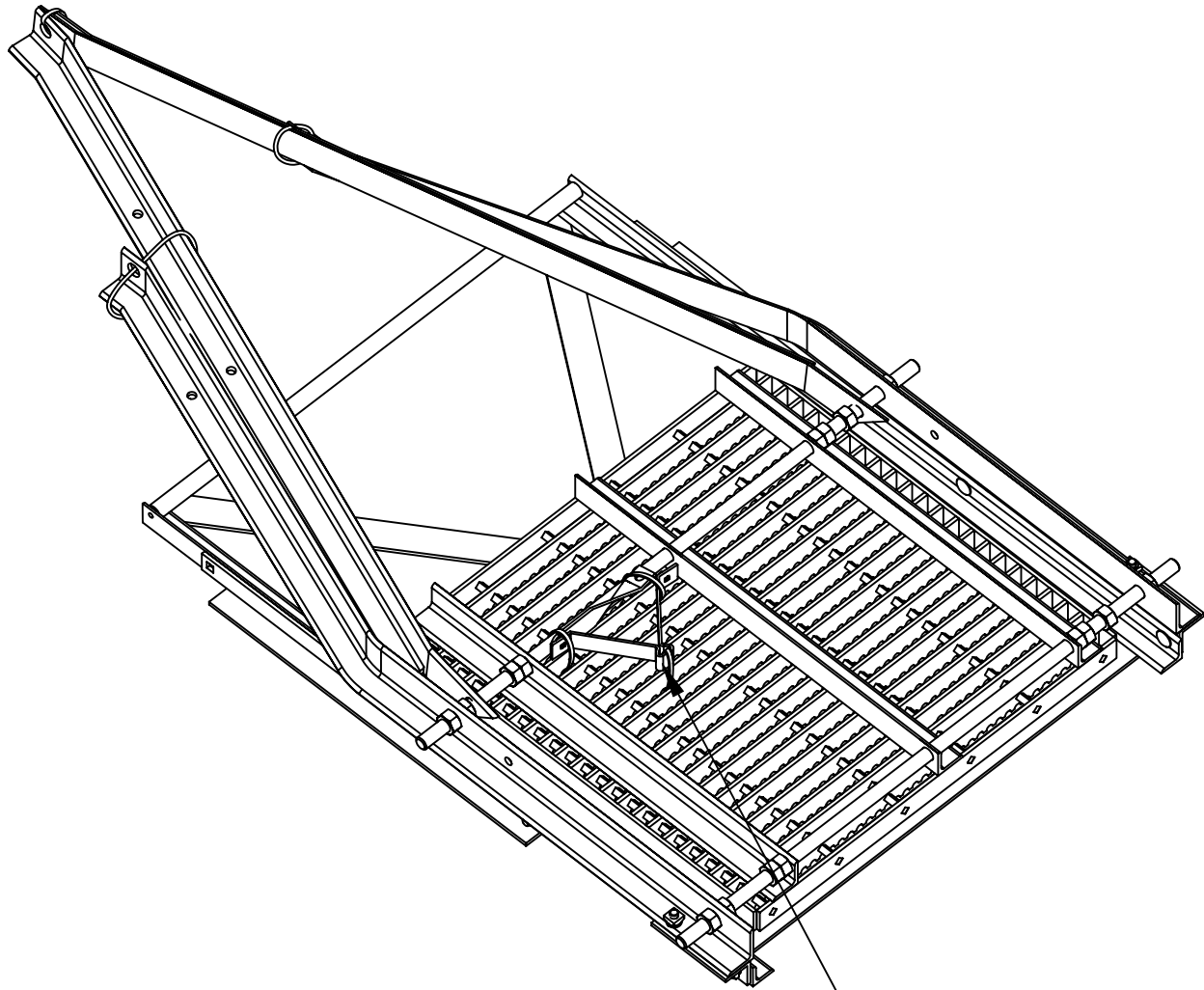

COMPONENTS SUPPLIED  
WITH BALCONY

### WARNING:

1. IT IS IMPERATIVE TO TRANSPORT THE BALCONY, AS RECEIVED FROM THE MANUFACTURER AND NOT UNPACK IT IN ANY WAY.
2. ONCE TRANSPORTED TO THE WORK LOCATION, REMOVE THE PACKING.

# STEP 2

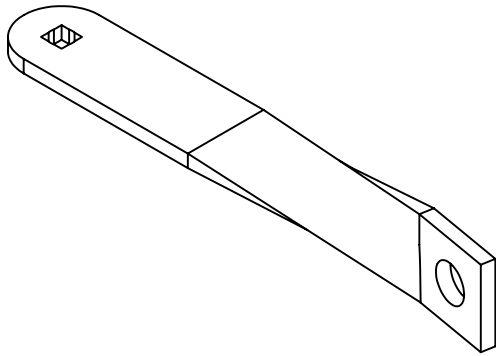

**A** POLE BRACE  
QUANTITY = 1

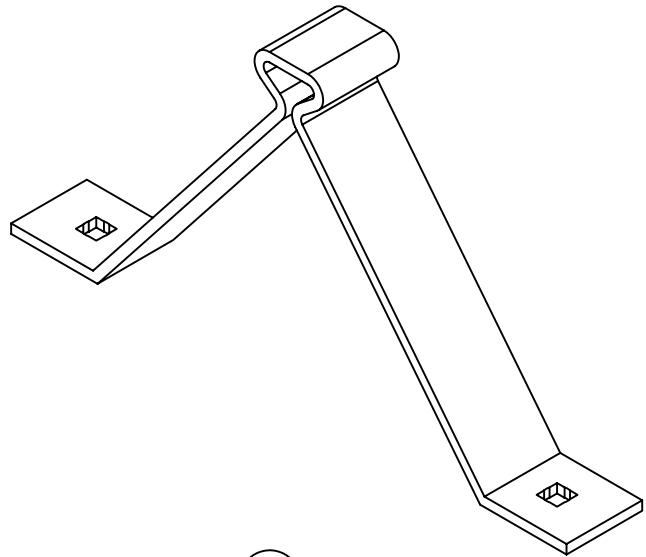

**B** STEP  
QUANTITY = 1

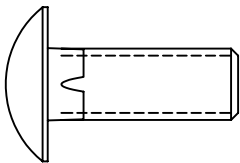

**1** 3/8-16 X 1" LG. CARRIAGE BOLT  
QUANTITY = 3

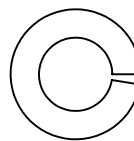

**2** 3/8 LOCK WASHER  
QUANTITY = 3

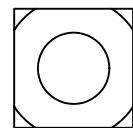

**3** 3/8-16 SQUARE NUT  
QUANTITY = 3

UNPACK THE COMPONENTS SUPPLIED WITH THE BALCONY AND LOCATE THE ABOVE PARTS.

# STEP 3

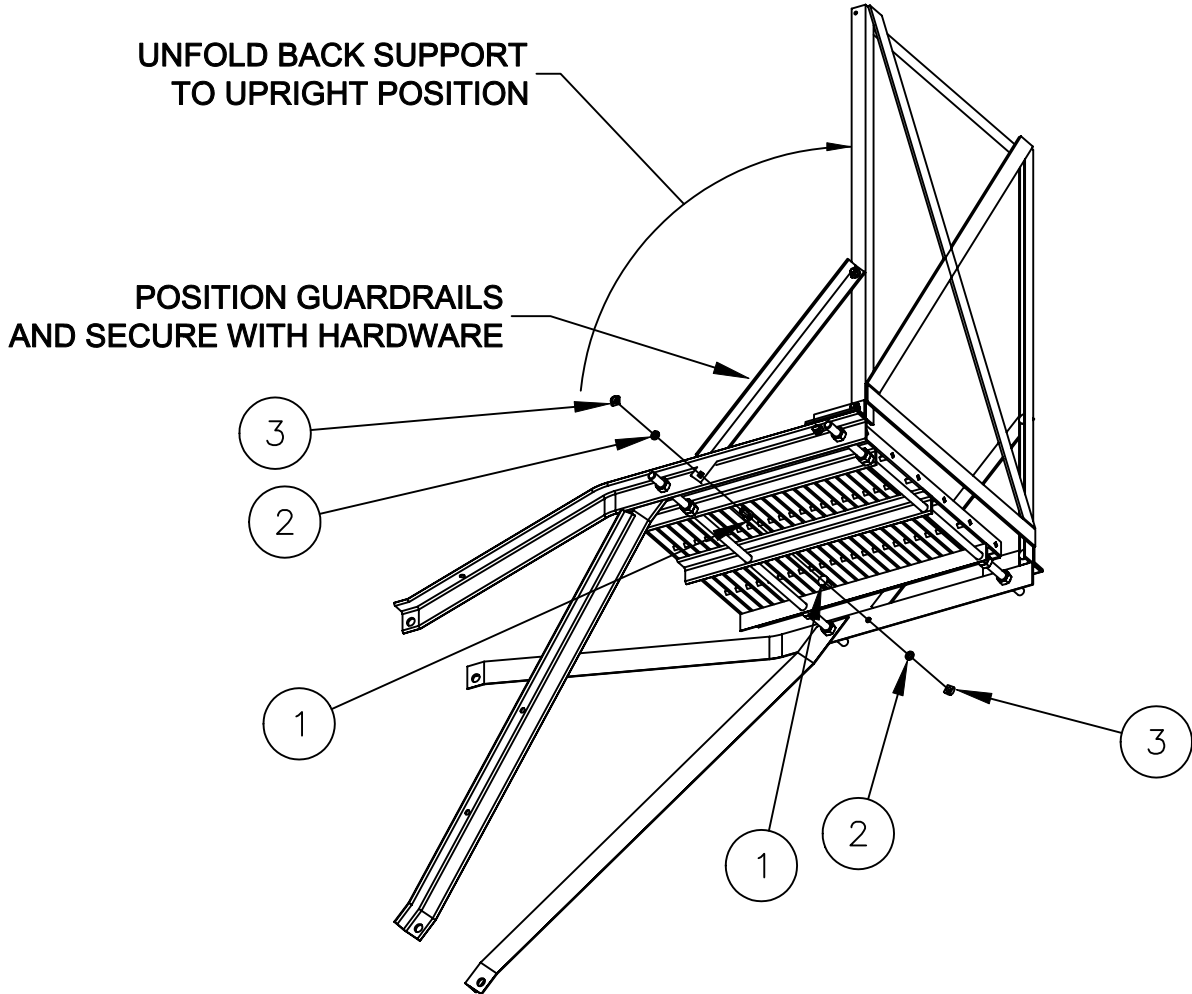

# STEP 4

ATTACH THE STEP, ITEM B, TO THE SLOPED BRACE DETERMINED TO BE THE ENTRANCE SIDE OF THE BALCONY BASED ON LOCAL OR CORPORATE SAFETY PROCEDURES USING THE HARDWARE INDICATED AND HAND TIGHTEN.

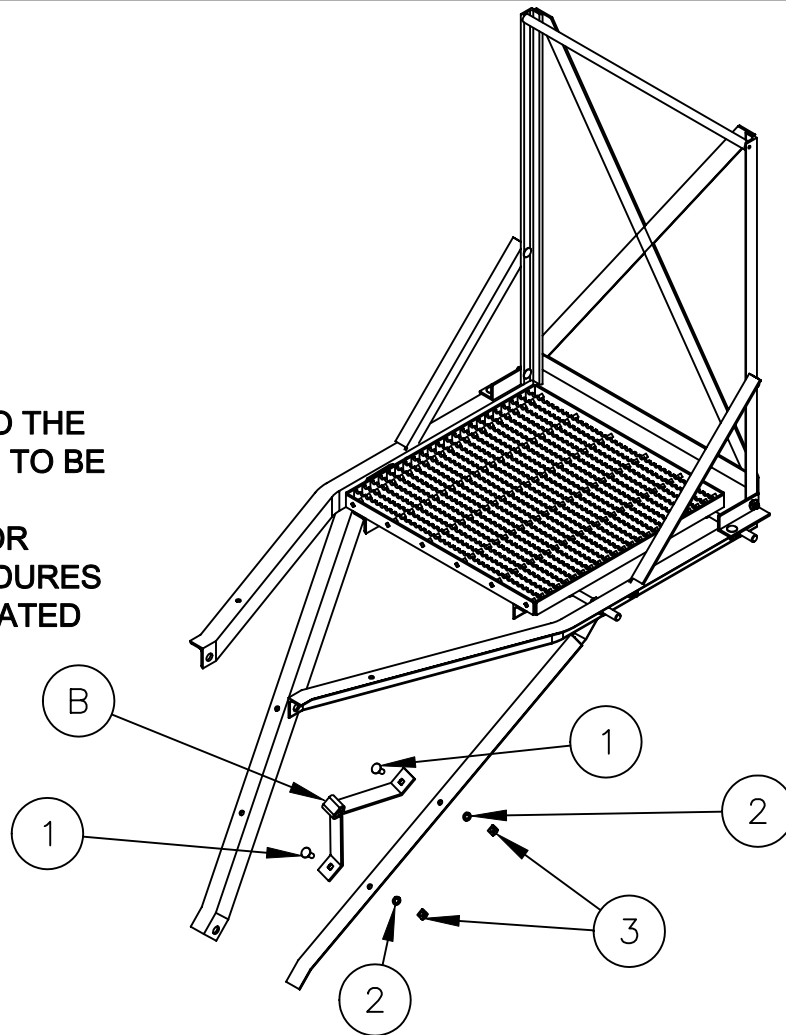

# STEP 5

RAISE THE BALCONY TO THE PROPER HEIGHT, ALIGNED WITH THE CONNECT/TERMINAL AND ATTACH THE BALCONY SUPPORT BRACKETS TO THE POLE USING APPROVED PROCEDURES AND HARDWARE ALLOWING 20 TO 30 INCHES CLEARANCE BELOW THE BOTTOM EDGE OF THE FDH CABINET OR 6 TO 8 INCHES BELOW THE BOTTOM EDGE OF THE SAI TERMINAL AND THE PLATFORM.

POSITION THE BALCONY TO A LEVEL HORIZONTAL POSITION AND ATTACH THE BOTTOM SUPPORT BRACKETS TO THE POLE USING APPROVED PROCEDURES AND HARDWARE.

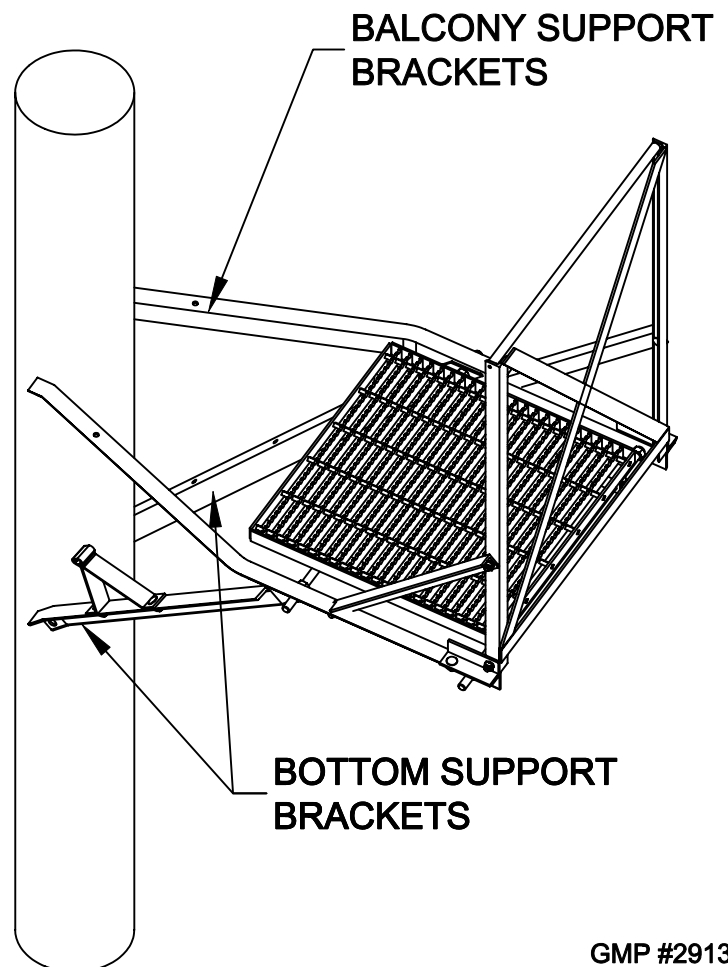

# STEP 6

ATTACH THE POLE BRACE, ITEM A, TO THE BALCONY USING THE HARDWARE INDICATED AND HAND TIGHTEN.

ATTACH THE POLE BRACE TO THE POLE USING APPROVED PROCEDURES AND HARDWARE.

**IMPORTANT! TIGHTEN ALL BOLTS.**

