

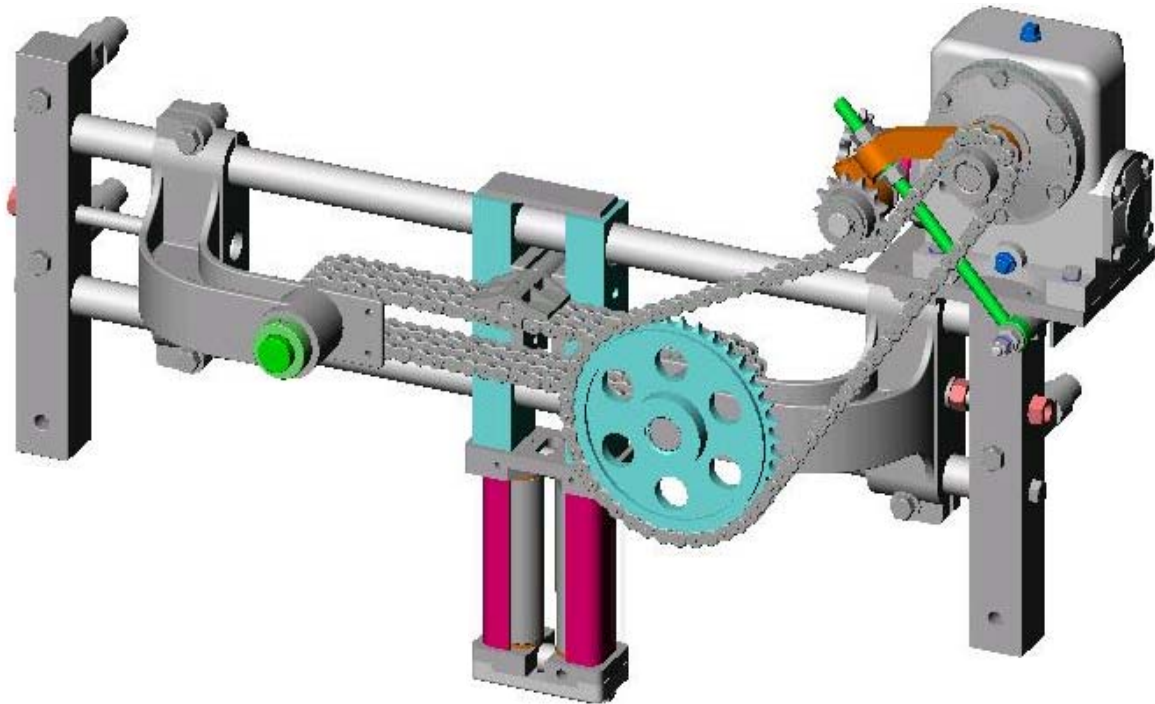

Adams Model CD3 & WG Rope Winder

INSTALLATION, OPERATION & MAINTENANCE



Copyright 2012 by General Machine Products Co., Inc

All rights reserved. No part of this publication may be copied, reproduced or transmitted in any form whatsoever without the written permission of General Machine Products Co., Inc.



GMP • 3111 Old Lincoln Hwy • Trevose, PA 19053 • USA
TEL: +1-215-357-5500 • FAX: +1-215-357-6216 • EMAIL: www.gmptools.com

July 17 2012 USA Ver 2
Manual P/N

SECTION	TABLE OF CONTENTS	PAGE
1.0	GENERAL INFORMATION	3
2.0	DESCRIPTION	3
3.0	OPERATION	3
4.0	PLACING WIRE ROPE ONTO THE WINCH DRUM	4
5.0	ADJUSTMENT	5
6.0	LUBRICATION	6
7.0	SPROCKET AND CHAIN SELECTION	6
8.0	WIRE ROPE	7
9.0	WIRE ROPE LUBRICATION	8
10.0	REPAIR PARTS	8
	PARTS IDENTIFICATION DRAWING	9
	PARTS LIST	10, 11
	REDUCER ASSEMBLY IDENTIFICATION	12

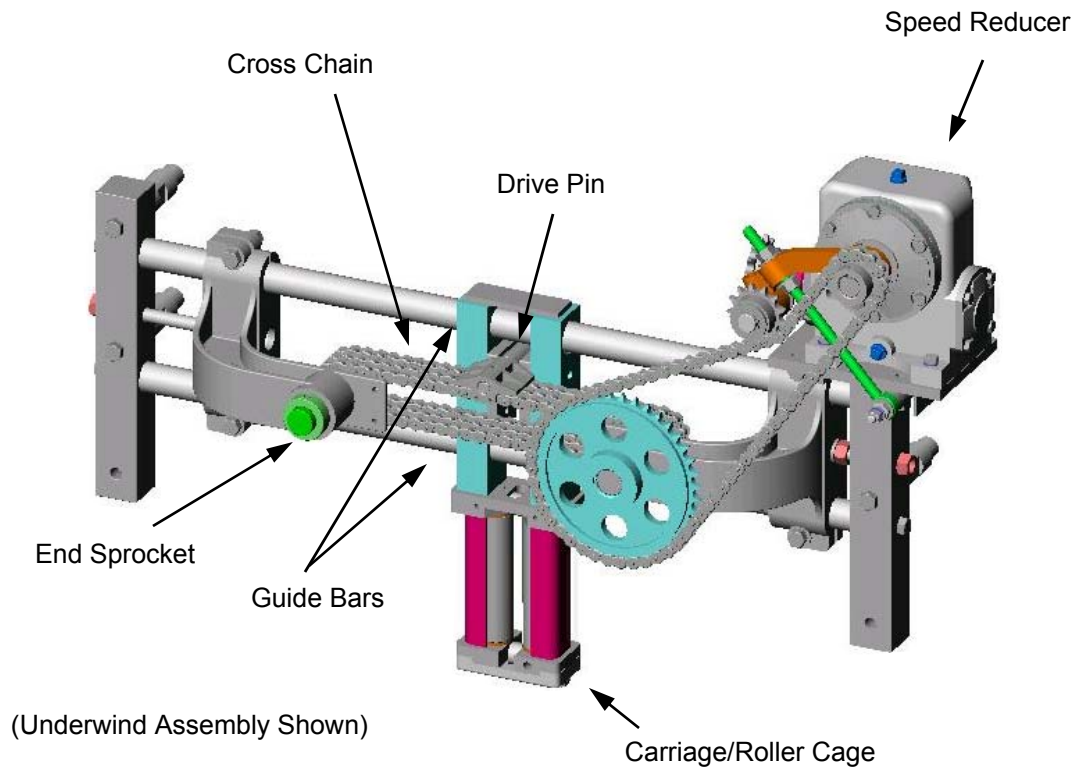

Figure 1

1. General Information

The Level Wind is a chain driven device specifically designed to distribute wire rope coils or wraps evenly across the winch drum.

Level winding the wire rope onto the drum has several advantages:

- Increases drum storage capacity.
- Prevents wire rope pileup.
- Permits smooth, steady pulls.
- Establishes tight, even wraps preventing the wire rope from cutting down through the lower lays resulting in damage to the rope and difficulty in unwinding.

2. Description

The level wind assembly includes a carriage/roller cage, guide bars, speed reducer, two single width and one triple width roller chain drive.

The carriage is mounted on two guide bars and is driven side to side across the drum by an endless triple width cross chain (*See Figure 1 on page 2*).

The carriage is connected to the cross chain by a drive pin which projects into a vertical slot in the carriage. As the cross chain rotates, it carries the drive pin and the carriage across the drum. When the drive pin reaches the end sprocket, it rotates around the sprocket moving up or down in the slot as required. Accordingly, the carriage and wire rope moves to the end of its travel and starts back again across the drum.

Positioned above the carriage (or below in the under wind configuration) is the roller cage assembly thru which the wire rope passes for final storage on the drum. The rollers are shielded with a roller guard for the purpose of operational safety.

3. Operation

The level wind is mechanically driven from the motion of the winch drum. Use caution to maintain uniformity and compactness of the wraps and lays of the wire rope on the drum at the start of the pull.

The carriage remains properly aligned because the level wind is mechanically driven directly from the winch drum. This is true of whether the rope is paying onto the drum under power or paying out under free spool conditions.

The speed of the carriage is regulated. For each revolution of the winch drum, the carriage advances across the drum a distance equal to the diameter of the rope.

Initially, the correct sprockets are determined by the factory relative to the nominal cable size that is specified for the winch. Due to minor variations in the diameter of the wire rope, the average diameter may have to be determined in order to modify the speed of the rope winder. Take several diameter measurements along the length of the wire rope, and call GMP to determine the correct sprocket combination.

Once a given set of sprockets has been established for a specific wire rope diameter, the rope diameter cannot be changed without a change in the sprocket teeth combination.

Constant tension must be maintained on the rope when operating the level wind. The amount of tension should be sufficient to eliminate "clock springing" that will lead to loose or tangled wraps and lays.

Under free spool conditions, if the drum has been permitted to over-run, resulting in loose or tangled wraps, remove several feet of improperly wrapped rope and rewind, under tension, prior to starting the actual pull. To insure good operation, the wraps and lays must always be straight and compact.

The winch is furnished with a caliper type drag brake. The brake is not designed to hold the load. The purpose of the brake is to control the drum rotation speed when paying out wire rope under free spool conditions. Slowing down and gradually stopping the drum, with tension on the rope, will prevent backlash, clock-springing and eventual entanglement of the rope.

For safety and convenience, the drag brake is equipped with a remote actuator. The remote actuator, reservoir and flexible hose section are shipped loose in the parts box. These components are to be installed by the dealer.

Although the level wind will guide the wire rope onto the drum from a relatively wide fleet angle, there will be less bending of the rope at the roller cage assembly if the line of pull is as straight as possible. Therefore, the use of a universal or universal swivel sheave on the tail shelf is advisable.

The roller cage assembly has only a sufficient amount of clearance for the rope to pass. When pulling in the wire rope, it is important that the operator stops the drum rotation at a point to keep the spliced eye or quick hook several feet from the roller cage. Otherwise, the eye and hook will be drawn into the roller cage, causing damage to the level wind.

If, for any reason, it is necessary to remove the wire rope from the roller cage while at a mid-point in the rope, it can be done by removing the roller cage top plate. First, remove the (2) hex bolts on the roller cage top plate then remove the top plate. Loosen the (2) set screws on either side of the mounting plate and remove the roller guide. The rope is then free.

4. Placing Wire Rope Onto The Winch Drum

Note: See section 8.0 for additional details on wire rope.

The timing of the level wind must be set properly when placing rope onto the drum. Set the timing of the level wind by rotating the drum until the carriage reaches a position of maximum travel at the drum end where the rope is to be attached. The extreme end of the carriage travel is when the guide link is on the outside of the end sprocket and at the mid-point of the vertical slot in the carriage. Thread the end of the rope through the roller cage and attach it to the drum by means of the rope clamp. See figure 2. Drive the winch forward at a low speed, keeping sufficient tension on the rope. It is extremely important that the first lay of rope be straight and compact. Slowly increase the drum speed and spool on the remaining rope.

Whenever possible, a winch line holder should be used to prevent the rope from unwinding.

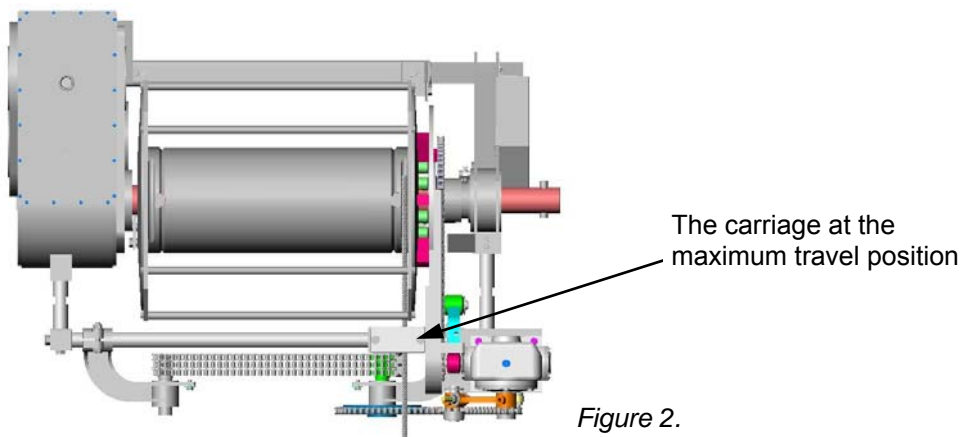

Figure 2.

5. Adjustment

The speed reducer input and output single width roller chain drives should be tight enough to prevent backlash but not excessively tight to cause bending of the reducer shafts. Special care should be taken when adjusting the first reduction chain. Rotate the drum (with the chain loose), to the point where the chain is at its tightest (its high spot). Adjust the chain idler to about 1/2 inch deflection in the chain. Next, rotate the drum a full turn to insure that the chain doesn't get tighter than the 1/2 in. deflection. A 1st reduction chain that's too tight will permanently bend the input shaft.

The triple width cross chain should be sufficiently tight to prevent tipping of the guide link. Any unsteady movement of the carriage could indicate a loose cross chain or lack of lubrication on the guide bars.

The cross chain should be adjusted an equal amount at both ends by the corresponding adjusting screw. The distance from the back of the chain to the inside of the drum must be equally spaced. See *Figure 3*.

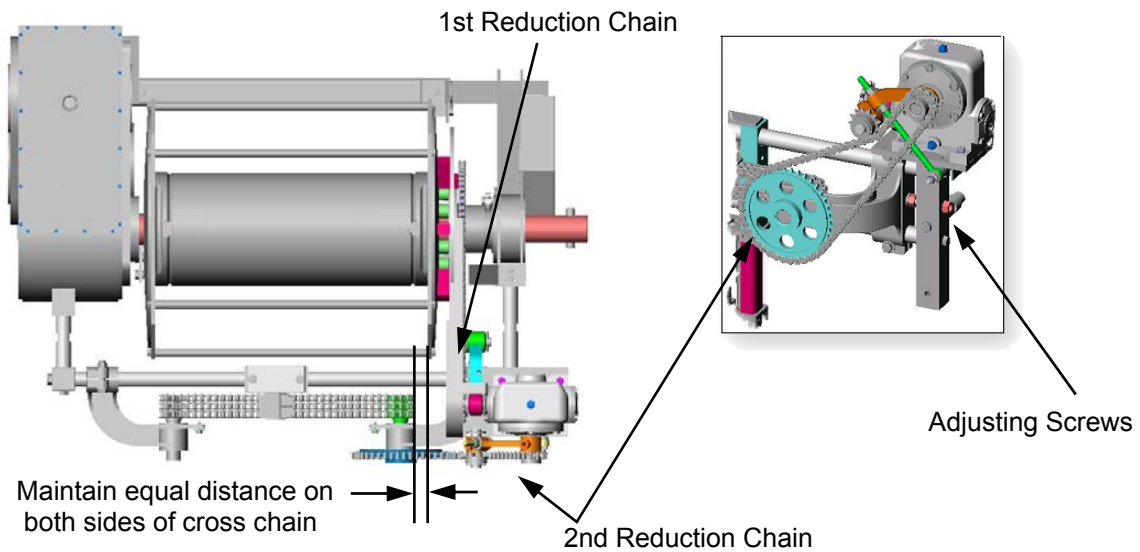

Figure 3.

The front chain drive (2nd reduction) from the speed reducer must be loosened before any adjustment is made to the cross chain.

Rotate the drum one revolution taking a measurement at four locations to check for equal spacing. Checking in four locations will compensate for any distortion in the drum flanges. Shift the cross chain assembly by turning the adjusting screws at each end after the lock nuts have been loosened.

If the rope piles up at one end and leaves an opening at the other end, shift the cross chain slightly away from the end where the rope piles up

The cross chain length is for an average drum width. If the rope piles up at both ends of the drum, the cross travel speed is too slow, or the cross chain length is too long. Remove one pitch from the cross chain and check for rope pileup at the ends of the drum. Make further adjustments to the cross chain length by removing additional links if necessary.

If the rope leaves an opening at both ends of the drum, the cross chain length is too short. Add one pitch to the cross chain and check for openings at the ends of the drum. Add additional links if necessary.

6. Lubrication

Every 3 months or seventy five (75) hours of operation, the level wind assembly should be lubricated in accordance with the instructions shown on *figure 4*.

Use standard motor oil in four oil cups marked "C", three roller chains (lubricated on the inside surface of the chain) coat the guide bars with a rust inhibitor such as LPS 3 Premier rust inhibitor or equivalent. Reapply the rust inhibitor to prevent corrosion once every month.

To check for the proper oil level in the speed reducer, remove the oil level plug in the side of the housing, lubricant should be maintained to the height of the oil level opening. Fill to the proper oil level with 80W140 oil or equivalent

To add oil, remove the oil level plug in the side of the housing. Remove the oil filler plug at the top of the housing. Add oil to the height of the oil level opening. Be sure to replace the plug at the top and on the side of the housing.

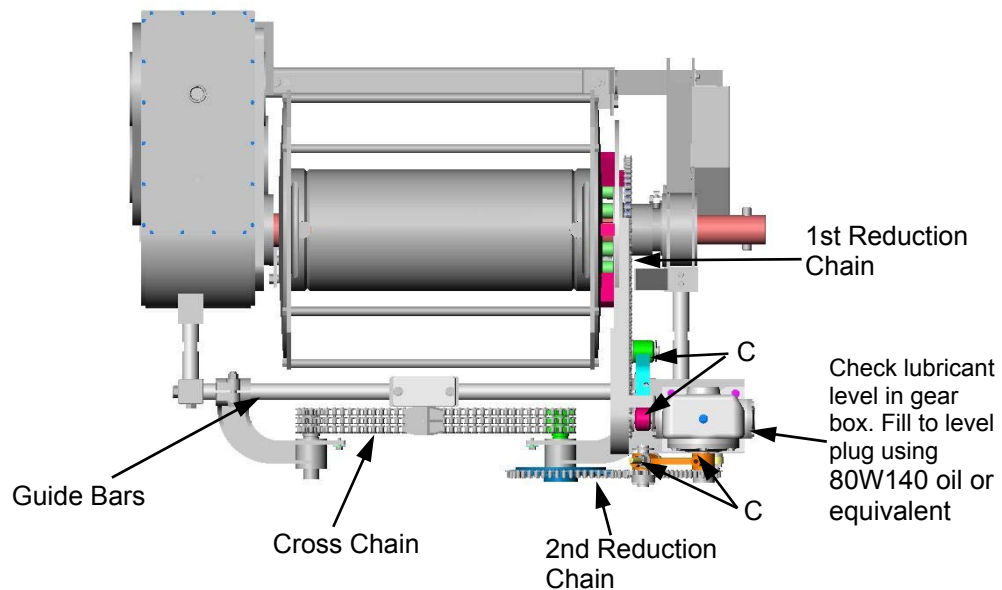

Figure 4.

7. Sprocket And Chain Selection

As previously specified, the number of teeth in the roller chain sprockets and the length of chain is fixed depending on the specific rope diameter being used.

NOTE:

- The WG winch is designed to accept 7/16" diameter wire rope only.
- American produced wire rope is never smaller than the nominal diameter, always larger with a plus tolerance of 1/32" in the size range used on GMP Adams Winches. Some foreign product may be smaller.
- Should synchronization difficulty be experienced with standard sprockets, measure the diameter of the wire rope in three locations with a micrometer and contact GMP.
- Sprockets and chains are 5/8" pitch, single width roller chain for the 1st and 2nd reduction.
- Sprockets and chains are 5/8" pitch, triple width roller chain for the cross chain.
- For the location of sprockets and chains see drawing on page 10.

To change the sprocket ratio to adjust for rope diameter tolerances,

1. Measure the wire rope in three different locations using a micrometer.
2. Contact GMP at 215-357-5500 and provide the wire rope diameter so the proper sprockets can be determined.
3. Follow the following procedure after the sprockets are received.
4. Remove the chain guards from the sprocket(s) to be changed. Be careful to not lose the hardware.
5. To loosen the chain loosen the jam nuts on the idler adjustment shaft.
6. Remove the chain connector and remove the chain from the sprocket(s) to be removed.
7. Loosen the set screw on the sprocket and remove the sprocket. Take note of the direction the hub is mounted on the shaft. Be careful not to lose the key.
8. Place new sprocket on the shaft with the key in the keyway in the shaft.
9. Align the new sprocket(s) by placing a straight edge on the sprockets to align them with each other.
10. Tighten the set screw on the new sprocket and the jam nuts on the idler sprocket adjustment shaft.
11. Place the chain on the sprocket and add chain connector.
12. Adjust the idler sprocket to take up any slack in the chain. Check the tension in the chain by rotating the drum by hand one complete revolution. Be careful not to over tighten the chain. There should be at least 1/2 in. slack at it's loosest position.
13. Replace the chain guards.
14. Set the timing of the level wind carriage by rotating the drum until the rope clamp is at the 12 to 1 o'clock position (6 to 7 o'clock for under-wind) when viewing the drum from the right side.
15. Position the carriage at a position of maximum travel at the drum end where the rope is to be attached. The extreme end of the carriage travel is when the guide link is on the outside of the end sprocket and at the mid-point of the vertical slot in the carriage.
16. Thread the end of the rope through the roller cage and attach it to the drum by means of the rope clamp. See *figure 2*.
17. Drive the winch forward at a low speed, keeping sufficient tension on the rope. It is extremely important that the first lay of rope be straight and compact. Slowly increase the drum speed and spool on the remaining rope.

Whenever possible, a winch line holder should be used to prevent the rope from unwinding.

8. Wire Rope

8.1 Spooling

- When installing the wire rope observe the following recommendations: It is important to select the correct winch rope for a particular application. Wire rope is specified by length, diameter, number of strands, number of wires per strand, type of center and type of lay. The purpose is to stress the importance of selecting the correct type of lay.
- There is a definite advantage in applying wire rope of the proper direction of lay when spooling onto the smooth surface of the winch drum. A rope with an improper lay may cause the coils will spread apart each time the load is removed. Installing the wire rope with the proper lay will tend to keep the coils together when the load tension is removed. The correct lay will develop tight coils and even layers.
- It is important to install the wire rope onto the winch drum with care. Kinking of the rope, caused by the rope taking a spiral shape as a result of an unnatural twist, should be avoided.
- When removing wire rope from the reel and spooling onto the winch drum, the reel must be supported on a horizontal axis and free to rotate. Spool the rope onto the drum with the natural bend in the same direction as it comes off the reel.
- If wire rope is received in a coil, it should be unwound with the coil in the vertical plane. Again, spool the rope onto the winch drum with the natural bend in the same direction as it was on the coil. Reverse bending of the wire rope should always be avoided or kept to a minimum.

IMPORTANT! Wire rope should always be under tension when spooling onto the winch drum.

- When the winch drum is in free spool and the drum shaft extension only is being used with a capstan or reel, pass the winch line through the tail shelf sheave and hook the pulling eye to a fixed section of the chassis. This will prevent the rope from unwinding or “clock-springing.”
- Likewise, when the winch is not in operation, attach the winch line quick hook to a solid member on the tail shelf and slowly take up the slack. This will best maintain the rope under a slight amount of tension until required again and will prevent the rope from unwinding or “clock-springing.”

8.2 Winch drum rotation:

Note: The CD3 is available in an UNDER WIND and OVER WIND configuration
The WG winch is only available in an UNDER WIND configuration.

Over winding – is when the winch drum rotates in a clockwise direction (viewing from the right side) and the wire rope is spooled onto the winch drum at the top. It is imperative that the wire rope be attached to the correct side of the drum for the specific direction of the lay of the rope given the direction of drum rotation. When the drum will be over winding as the wire rope is spooled in, use the rope clamp on the side of the drum which is the same as the lay of the wire rope. For example, if using right lay rope on an over wind drum attach the wire rope to the right side rope clamp.

Under winding – is when the winch drum rotates in a counterclockwise direction (viewing from the right side) and the wire rope is spooled onto the winch drum at the bottom. Once again, it is imperative that the wire rope be attached to the correct side of the drum for the specific direction of the lay of the rope given the direction of drum rotation. When the drum will be under winding as the wire rope is spooled in, use the rope clamp on the side of the drum which is opposite of the lay of the wire rope. For example, if using right lay rope on an under wind drum attach the wire rope to the left side rope clamp.

The wire rope must be guided and maintained as it is routed forward under the body deck to the winch drum. This can be done by using a trough or tube with sufficient width at the front and depending on the angle of incline combined with the body cross-member configuration, a floating sheave or roller may be required. Application engineering assistance is available from GMP.

WARNING! The cable clamp alone is not designed to hold the rated load. Approximately ½ of the first layer of winch line must be left on the drum to achieve the rated load and avoid cable clamp failure.

9 Lubrication:

- Wire rope is considered to be a machine, having many moving parts. Each time the rope bends or flexes, the various wires and strands slide over each other. Lubrication is required to facilitate this movement.
- The type of lubricant, method of applying and frequency of application is dependent on each particular circumstance. For specific lubrication details contact the wire rope manufacturer.

10 Repair Parts:

- For item location, refer to Page 9.
- For part identification refer to parts list on Pages 10 thru 12.

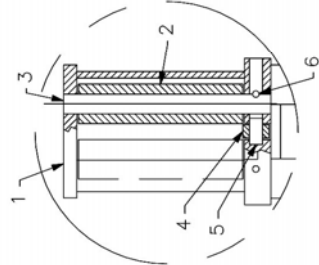
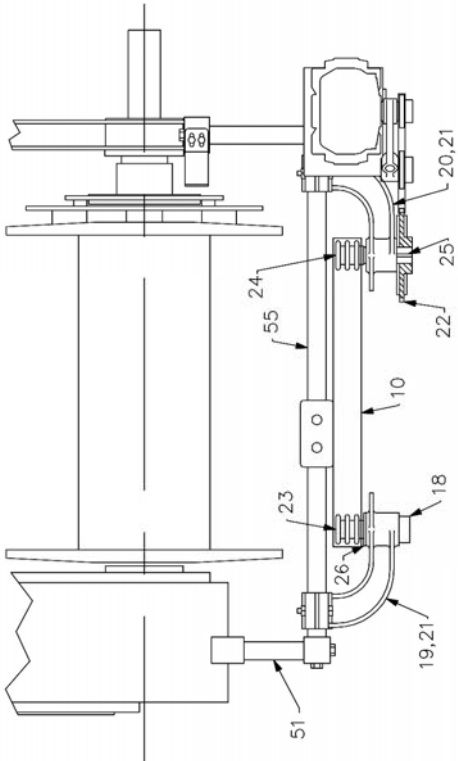
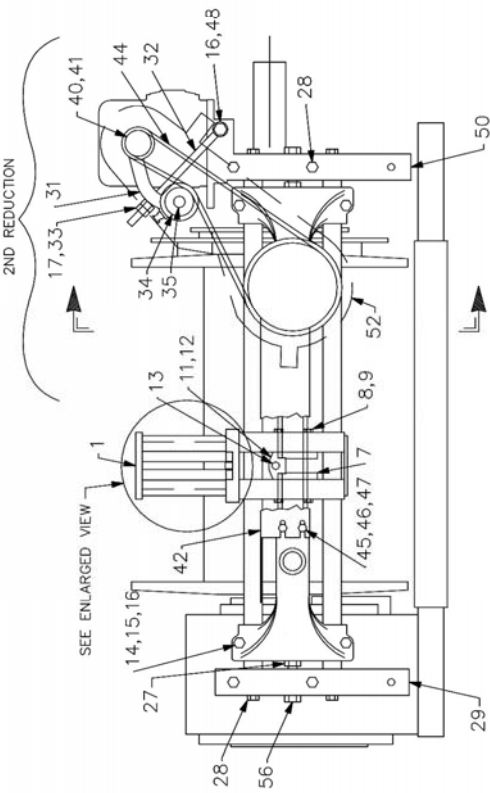
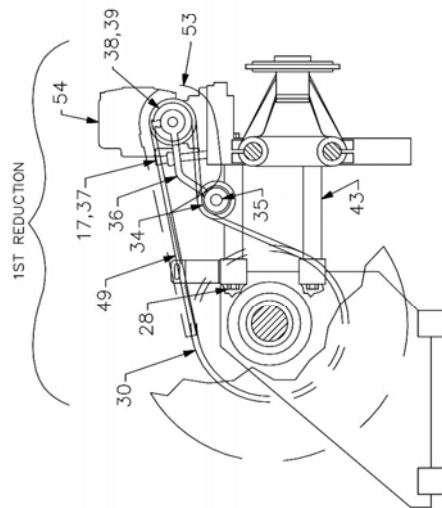

ENLARGED VIEW

- NOTES:
1. SOME COMPONENTS NOT SHOWN IN ALL VIEWS FOR CLARITY.
 2. UNDERWIND APPLICATION NOT SHOWN, ALL COMPONENTS FOR OVERWIND AND UNDERWIND ARE IDENTICAL EXCEPT FOR ITEMS 1, 2, 3, 48 AND 53.
 3. REFERENCE PARTS LIST FOR 30435 ISSUE 1, DATED 7/95.

GENERAL MACHINE PRODUCTS CO. INC. TREVOSTE, PA. 19053		CAD GENERATED DWG.	
MODEL CH LEVELWIND		SCALE	
MODEL CD3 WINCHES		DATE	2/95
DRAWN BY	C.J. KING	SHT. OF SHT.	1
DWG. NO.	30435	ISSUE	1

Refer to Drawing # 30435 on Page 9

Item No.	Part No.	Description	Req'd Qty.
1	26459	Carriage assembly (CD3 over wind, WG over and under wind) Includes items 2A, 3A, 4, 5, 6 Assy	1
	26460	Carriage assembly (CD3 under wind) Includes items 2A, 3A, 4, 5, 6 Assy	1
2	25869	Roller Assembly (WG, CD3 over wind)	2
	25870	Roller Assembly (CD3 under wind only)	2
3	25858	Shaft (WG, CD3 over wind)	2
	25862	Shaft (CD3 under wind only)	2
4	25848	Guide Roller	1
5	25850	Shaft Guide Roller	1
6	09983	Roll pin 1/4" x 2" Long	2
7	14926	Guide Plate	2
8	16755	Cap Screw Hex Hd 3/8-24 x 2" Long	4
9	16449	3/8" Lock washer SAE medium	4
10	29764	WG Cross Chain Assembly 5/8 Pitch 60 Pitches Triple Width Roller Chain, Includes Items 11 & 12	1
	34336	CD3 Cross Chain Assembly 5/8 Pitch 74 Pitches Triple Width Roller Chain, Includes Items 11 & 12	1
11	14952	Guide Link	1
12	14951	Connecting Pin	2
13	14927	Driving Pin	1
14	16938	Cap Screw Hex Head 1/2-20 x 2 1/2"	4
15	17591	Nut Hex 1/2-20	4
16	09324	1/2" Lock Washer SAE medium	5
17	17575	Nut Jam Steel 1/2-13	3
18	16762	Collar W/Set Screw	1
19	15585	Bracket Assembly w/Item 21	2
20		Same as item #19	
21	16723	Bushing Oilite For Item 19	2
22	14949	Sprocket w/Set screw 40 Teeth for 7/16", 1/2" wire rope	1
	14972	Sprocket w/Set screw 36 Teeth for 5/16", 3/8", 9/16" wire rope	
23	14925	Sprocket 10 Teeth, 5/8" Pitch Triple Width Roller Chain, Short	1
24	14924	Sprocket 10 Teeth, 5/8" Pitch Triple Width Roller Chain, Long with keyway	1
25	16734	Woodruff Key 5/16" x 1" For Items 22 & 24	1 EA.
26	14973	Washer, Thrust (spacer)	2
27	09043	Nut, Jam 5/8"-18	2
28	17837	Cap Screw Hex Head 1/2-20 x 1 3/4"	10
29	26061	Guide Rod Support	1
30	14915	Sprocket (Replacement) For Winch Drum 58 Teeth 5/8" Pitch Roller Chain	1
	24211	Sprocket as above split for replacement on mounted winch. Must be welded in place	1
31	15593	Idler Bracket Assembly Second Reduction Includes: 1 #14965 230-1003 Idler Bracket 2 #16724 110B Oil Cup 1 #16746 AA1110-12 Bushing Oilite 1 #16747 AA1108-16 Bushing Oilite	1

Refer to Drawing # 30435 on Page 9

Item No.	Part No.	Description	Req'd Qty.
32	16744	Idler Adjusting Rod	1
33	09794	1/2" Washer Flat	1
34	14962	Sprocket Idler 13 Teeth 5/8" Pitch Roller Chain With Set Screw	2
35	15594	Idler Shaft Assembly Includes: 1 #14966 230-1541 Idler Shaft 2 #16748 5160-87 Snap Ring 1 #16749 7/8" ID x 1 3/4" OD x .15 Thick Flat Washer	2
36	15591	Idler Bracket Assembly First Reduction Includes: 1 #14961 141-S-96 Idler Bracket 2 #16724 110-B Oil Cup 1 #16743 A1106-3 Bushing Oilite 1 #16742 A1108-10 Bushing Oilite	1
37	17888	Square Head Round Point Set Screw 1/2"-13 x 4" Long	1
38	16760 16738 16892 16766	First Reduction Driven Sprocket, 14 Teeth With Set Screw for 1/2", 9/16" wire rope First Reduction Driven Sprocket, 16 Teeth With Set Screw for 7/16" wire rope First Reduction Driven Sprocket, 19 Teeth With Set Screw for 3/8" wire rope First Reduction Driven Sprocket, 23 Teeth With Set Screw for 5/16" wire rope	1
39	17839	Key 3/16" Square x 1" Long	1
40	16767 16739	Second Reduction Drive Sprocket, 11 Teeth With Set Screw for 5/16", 3/8" wire rope Second Reduction Drive Sprocket, 12 Teeth With Set Screw for 7/16", 1/2", 9/16" wire rope	1
	16751	Key 1/4" Square x 1" Long	1
42	28818 26295	Cross Chain Guard 19" drum WG Cross Chain Guard drum CD3	1
43	28785 26132	Support Shaft Level wind – Hanger Side WG Support Shaft Level wind – Hanger Side CD3	2 2
44	14967	Second Reduction 5/8" Roller Chain: 80 Pitches Includes Connection Link.	1
45	16727	Cap Screw Hex Head 5/16-24 x 3/4" Long	4
46	05040	5/16" Lock Washer SAE Medium	4
47	02244	3/8" Flat Washer	4
48	14963	Stud	1
49	25236 25235	1st Reduction Roller Chain: 107 Pitches Includes Connecting Link. (WG, CD3 under wind) 1st Reduction Roller Chain: 97 Pitches Includes Connecting Link. (CD3 over wind)	1
50	26065	Pedestal Rod Support	1
51	28785 26131	Support Shaft Level wind - WG Housing Support Shaft Level wind - CD3 Housing	2 2
52	14969	Chain Guard Second Reduction With Brackets -WG, CD3	1
53	28310	Chain Guard First Reduction With Brackets WG, CD3	1
54	14964	Reducer Assembly Right-Hand	1
55	28817 26074	Tie Rod Level Wind WG Tie Rod Level Wind CD3	2 2
56	30286	Adjusting Rod 4" Long (1 per WG) (2 per CD3)	AR
56	28822	Adjusting Rod 7" Long -Housing Side - (1 per WG) (not used on CD3)	AR
#	28777	Mounting Weldment Level Wind LH - WG	1
#	28782	Mounting Weldment Level Wind RH- WG	1

Winch Rope Winder Reducer Assembly

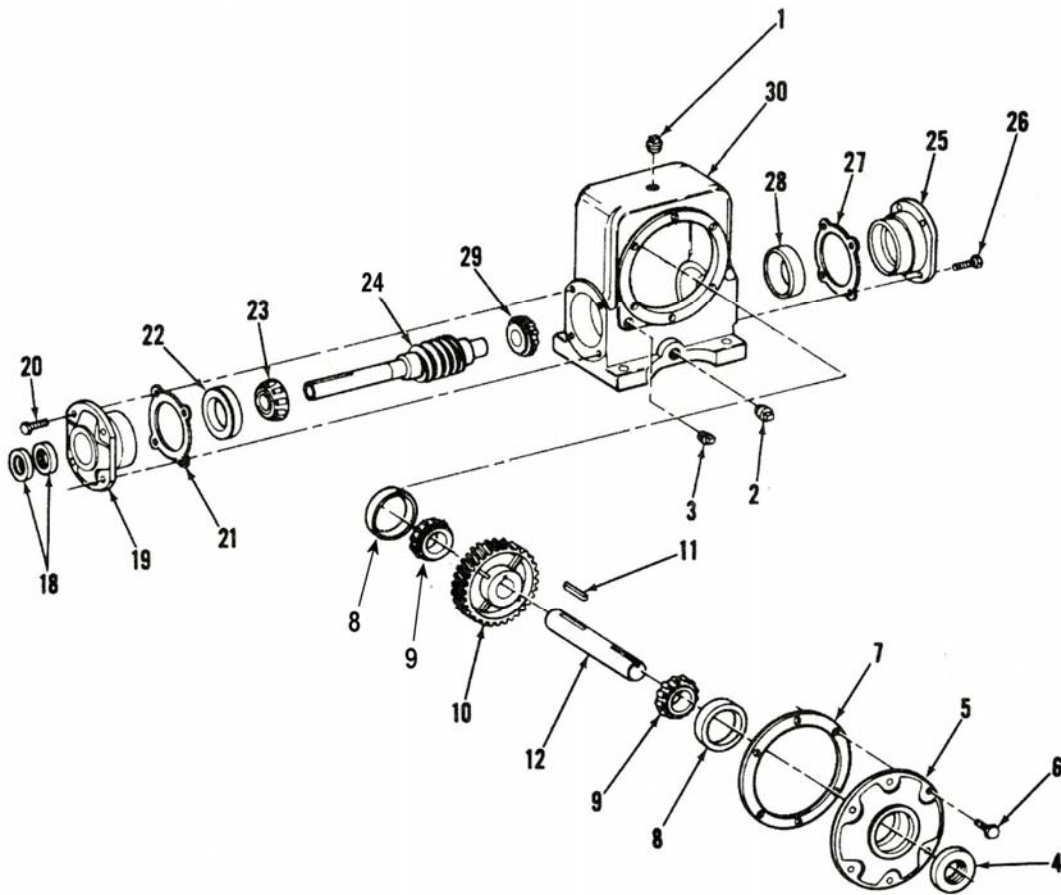

Item #	Part #	Description	Qty.	Item #	Part #	Description	Qty.
1	15982	Plug, Breather	1	17	xx	Not used	
2	16442	Plug, Drain	1	18	16447	Seal, Oil	2
3	16888	Plug, Oil	1	19	15975	Carrier, Open Bearing	1
4	16448	Seal, Oil	1	20	16033	Bolt, Hex Hd 5/16-18x3/4	4
5	15976	Carrier, Open Bearing	1	21	17140	Gasket, Shim .005 (blue)	AR
6	16033	Bolt, Hex Hd 5/16-18x3/4	6	21	15980	Gasket, Shim .020 (yellow)	AR
7	15981	Gasket	AR	22	16446	Cup	1
8	16445	Cup	2	23	16444	Cone	1
9	16443	Cone	2	24	15965	Shaft, Worm	1
10	15977	Gear, Worm	1	25	15973	Carrier, Closed Bearing	1
11	15978	Key	1	26	16033	Bolt, Hex Hd 5/16-18x3/4	4
12	15979	Shaft, Worm Gear	1	27	17140	Gasket, Shim .005 (blue)	AR
13	xx	Not used		27	15980	Gasket, Shim .020 (yellow)	AR
14	xx	Not used		28	16446	Cup	1
15	xx	Not used		29	16444	Cone	1
16	xx	Not used		30	15974	Housing	1

GMP Limited Warranty

1a. General Machine Products Co., Inc. ("GMP") warrants to the purchaser and/or end user:

(1) that a new product sold and manufactured by GMP will be free from original defects in material and workmanship for one year from the date the product was delivered to the purchaser and/or end user, or for the lifetime of the Modular Plug Presser;

(2) that a new product sold and not manufactured by GMP will be covered exclusively by the manufacturer's warranty. However, if that warranty coverage shall provide less coverage than the GMP Warranty for its manufactured products, then the warranty set forth in Paragraph 1(a)(1) above shall apply instead;

(3) that a reconditioned used GMP product sold by GMP, or a non-owned product repaired by GMP, or a new part sold by GMP, will be free from original defects in material and workmanship for ninety days from the date the product was delivered to the purchaser and/or end user.

1b. The above warranties are contingent upon and subject to the condition that: (1) the end user substantiates the date it purchased and received delivery of the product or part, and (2) the product or part shall have been installed, maintained and used in accordance with GMP's or the manufacturer's written instructions.

2. The end user shall determine the suitability of GMP's product or part for intended use, and the end user assumes all risk and liability whatsoever in connection therewith except to the extent set forth in this Limited Warranty.

3a. GMP reserves the right to request that the product or part be returned to us for examination and cannot be responsible for user charges incurred in the replacement of any product. GMP's agreement to repair or replace is also subject to its inspection of the product and verification of the defect.

3b. Subject to immediate written notification of a defect or malfunction, GMP will repair or replace that product or part, at GMP's option, returned freight prepaid to Trevoise, PA.

3c. To obtain repair or replacement service under the Limited Warranty, the purchaser must contact the factory for a Return Material Authorization (RMA). Once obtained, send the RMA along with the defective part or product, transportation prepaid to:

General Machine Products Co., Inc.

3111 Old Lincoln Highway
Trevoise, PA 19053 USA
Tel: 215.357.5500

3d. The field labor and material charges incurred by an authorized GMP dealer or an end user to disassemble, inspect, repair and reassemble our product or part at their respective prime locations will not be reimbursed unless GMP has first reviewed and approved those charges.

3e. Incidental repair charges incurred by an authorized dealer or an end user for items such as labor, transportation, tolls, lodging and meals at a location remote from its prime facility, or to demount our product or part from its remote location and forward to its prime facility, are not the responsibility of GMP, and are not covered by this Warranty.

3f. Incidental repair charges incurred by an authorized GMP dealer or end user to remove construction hardware, modify a vehicle or otherwise gain access to GMP's product or part, is a condition beyond GMP's control, and is not covered by this Warranty.

4a. GMP products or parts which become part of a total assembly which has been designated and/or manufactured by others, are not covered by this Warranty unless GMP reviews the total assembly and expressly extends its warranty.

4b. Design, material and workmanship furnished by others to install or operate a GMP product or part are not covered by this Warranty with respect to GMP's products or parts which are used in that particular assembly.

4c. Hydraulic, pneumatic, electrical or mechanical control equipment which is not manufactured by GMP and which becomes a part of a GMP assembly, is not covered by this Warranty.

4d. This warranty does not cover a GMP product or part which others have subjected to abuse, improper installation, improper operation, alteration or negligence in storage or handling.

5a. THE ABOVE WARRANTIES ARE EXCLUSIVE AND ARE IN LIEU OF ALL WARRANTIES OF MERCHANTABILITY, FITNESS FOR PURPOSE OR OTHER WARRANTIES OR GUARANTEES OF ANY KIND OR DESCRIPTION, EXPRESS OR IMPLIED.

5b. GMP ASSUMES NO LIABILITY WHATSOEVER, INCLUDING WITHOUT LIMITATION, ANY INJURY, LOSS OR DAMAGE, IN CONNECTION WITH THE INSTALLATION OR USE OF THIS PRODUCT OR PART, EXCEPT AS STATED IN THIS LIMITED WARRANTY. GMP WILL IN NO EVENT BE LIABLE FOR DIRECT, INDIRECT, SPECIAL, INCIDENTAL OR CONSEQUENTIAL DAMAGES ARISING OUT OF THE USE OR INABILITY TO USE THE PRODUCT OR PART.

5c. GMP'S SOLE LIABILITY AND THE PURCHASER'S SOLE REMEDY FOR A FAILURE OF A PRODUCT OR PART UNDER THIS LIMITED WARRANTY, AND FOR ANY AND ALL CLAIMS ARISING OUT OF THE PURCHASE AND USE OF THE PRODUCT OR PART SHALL BE LIMITED TO THE REPAIR OR REPLACEMENT OF THE PRODUCT OR PART THAT DOES NOT CONFORM TO THIS WARRANTY.

6. GMP reserves the right, without notice, to make changes in equipment design or components as progress in engineering or manufacturing methods may warrant.

7. This Warranty shall be construed in accordance with the laws of the State of Pennsylvania, of The United States of America.

8. This Limited Warranty may not be modified, in whole or in part, except by writing signed by an authorized officer of GMP.



General Machine Products Co., Inc.
3111 Old Lincoln Highway
Trevose, PA 19053 USA
TEL: 215-357-5500
FAX: 215-357-6216
E-MAIL: info@GMPtools.com
WEB: <http://www.GMPtools.com>

GMP reserves the right, without notice, to make changes in equipment design or components as progress in engineering or manufacturing methods may warrant.
All contents ©2012 GMP