

B Pressure Ell Typical Usage

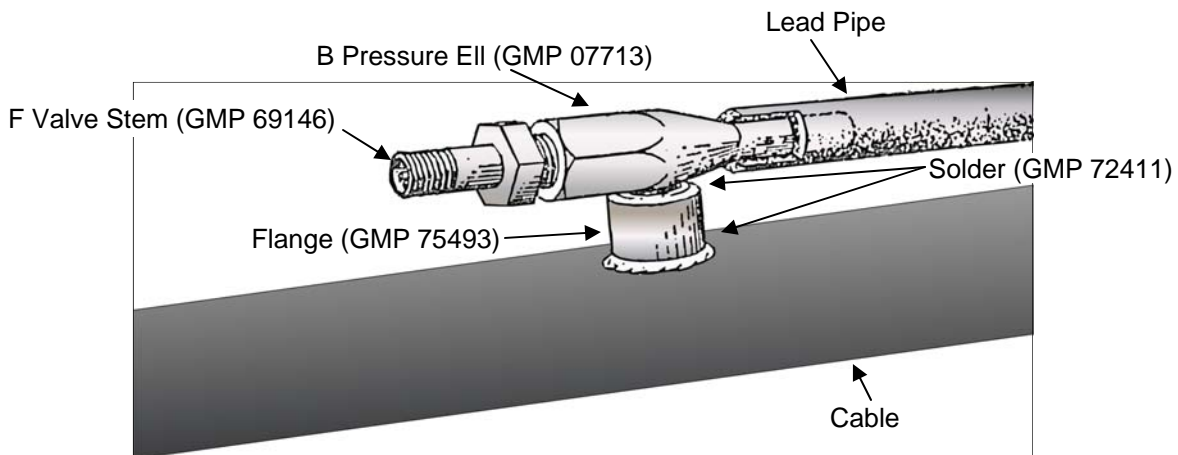

The B Pressure Ell may also be used on a splice case or "T" type cable terminal. When used on a splice case or "T" type terminal approximately 3/8 inch of the pipe stem on the B Pressure Ell should be cut off. This is necessary to allow the end of the pipe stem to clear the projections on the splice case when it is being screwed into the flange on the case. A hack saw may be used for cutting off the pipe stem, but care should be taken to remove all metal deposits after sawing is completed. To install the B Pressure Ell in a splice case, clean the pipe stem of the ell and coat it with stearine. Coat the threads of the ell with an approved pipe joint compound and screw the Ell into the pressure testing flange on the splice case. Make certain the lead pipe is clean and dry. Push the end of the lead pipe onto the pipe stem of the B Pressure Ell and solder in place, using C Stearine Core Solder. Insert the F Valve Stem after soldering of the lead pipe and pipe stem. (See illustration below.)

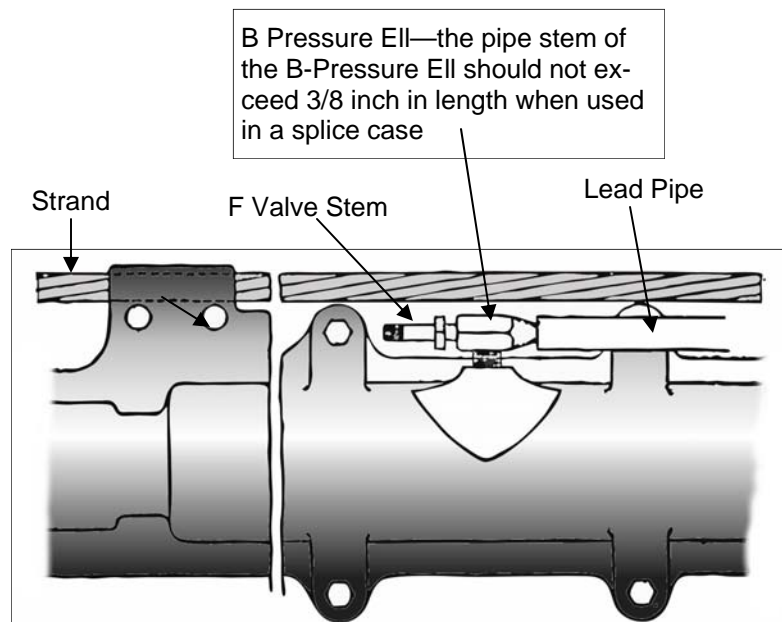

Where required, install an F Valve Stem into the female threaded hole of the B Pressure Ell. Otherwise, close the Ell with a C Pressure Flange Plug. In either event coat the threads with pipe joint compound before assembly.