

Assembly Procedure for the CD28/CD22 Detented Clutch

1. Rotate winch drum shaft so that the hole in the spline is at 12 and 6 o'clock.
2. Place large spring on shaft and followed by clutch assembly (clutch plate and sleeve) with the holes in its spline also aligned at 12 and 6 o'clock.
3. Push clutch against spring as close to drum as possible. Rotate drum so that the drive lugs are in line with clutch's lugs to prevent the spring from pushing the clutch back out. Place wedge between any pair of lugs to place more pressure on spring and move plate as close as possible to the drum.
4. Refer to illustration 1. Rotate the sleeve and slide towards drum so that the 17/32 hole is on the bottom (6 o'clock). Push one 17/32 ball up in the hole until seated in clutch plate. Rotate sleeve around to top (12 o'clock). Place second 17/32 ball in hole and let it drop in sleeve.
5. Refer to illustration 2. Slide the sleeve away from the drum. Rotate sleeve so that the large hole is at the bottom 6 o'clock position. Push one 11/16 ball up in hole until seated in clutch plate.. Rotate the sleeve so that the large hole is now on the top at 12 o'clock.
6. Looking down through the hole, place one detent with rounded end down through the hole in the shaft.
7. Next place detent spring into the hole.
8. Place second detent over spring with rounded end up.
9. Push second 11/16 ball over detent and rotate sleeve so that the ball puts pressure on the spring.
10. Rotate sleeve so that either one of the 1/2 x 20 threaded holes are aligned with the slot in the clutch plate.
11. Insert the sleeve locking screw with lock washer. Tighten making sure that the unthreaded tip aligns with the slot in the clutch plate.
12. Plug second hole with the 1/2-20x5/8 screw and star washer.
13. Screw in pipe plug flush with top of sleeve.

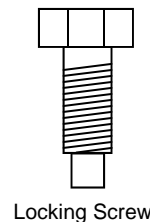
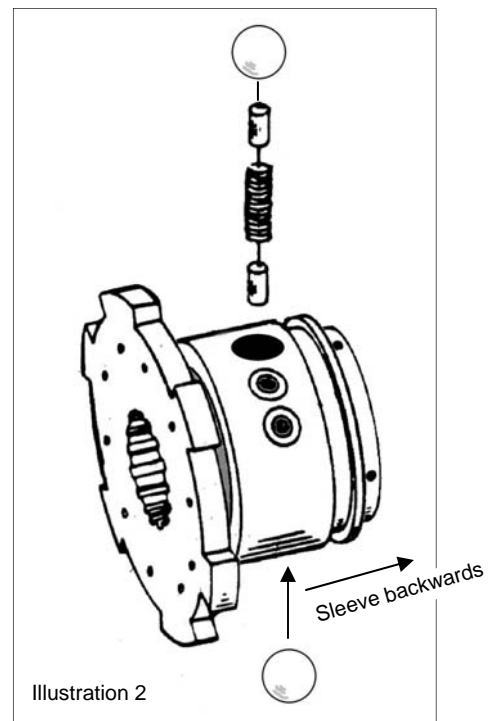
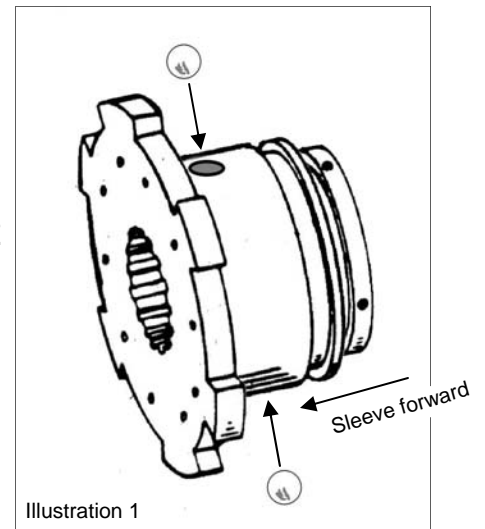

Locking Screw